

BlueStream™



D15 - Control Valve



**Please read this manual carefully before
the installing the system.**

LEGACY VIEW

SETUP

CONTROL

VIEW HISTORY

MODIFY SETTINGS

MONITOR WATER USAGE



TABLE OF CONTENTS

Table of Contents.....	3
Valves Specifications.....	4
Legacy View Control Start Up Procedure.....	5
Advance Settings.....	6
Status History	9
Salt Monitoring Update.....	10
Main Menu.....	15
Normal Operation.....	17
Master Programming Mode.....	19
Filter Master Programming.....	21
Aeration Master Programming.....	24
Cabinet Softener Breakdown.....	27
Filter Breakdown.....	31
Aeration Breakdown.....	33
Side Valve Breakdown.....	36
Bypass Assembly.....	40
Service Instructions.....	41
Error Codes.....	42
Troubleshooting.....	43
Valve Dimensions.....	44
Warranty.....	46

WARNING:

Lubricants

Do NOT use Vaseline, oils, hydrocarbon lubricants or spray silicone anywhere! Petroleum base lubricants will cause swelling of o-rings and seals. The use of other lubricants may attack plastic Noryl®. It is recommended that Dow

Corning® silicone grease be used as a lubricant for all control valves. Dow Corning® 7 Release Compound is used in the manufacture of Chandler Systems control valves. (Part # LT-150)

Sealants

Pipe dope and liquid thread sealers may contain a carrier that attacks some plastic materials. It is recommended that only Teflon® tape be used to seal plastic Noryl® threaded fittings.

Valve specifications

D15 Valve Specifications	
Valve Material	Noryl®*
Inlet / Outlet	3/4" - 1"
Cycles	5
Flow Rates (50 psi inlet) - Valve Alone	
Continuous (15 psi drop)	21 gpm
Peak (25 psi drop)	27 gpm
CV (flow at 1 psi drop)	5.4
Max. backwash (25 psi drop)	17 GPM
Regeneration - Downflow	
Adjustable Cycles	Yes
Time Available	99 minutes per cycle
Meter Information	
Meter Accuracy Range	.25 - 15 gpm +/- 5%
Meter Capacity Range (gal.)	1 - 9,999
Dimensions	
Distributor Pilot	1.050" O.D.
Drain Line	1/2" NPT Q.C.
Brine Line	3/8"
Mounting Base	2-1/2" - 8 NPSM
Height From Top of Tank	7.7"
Typical Applications	
Water Softener	6" - 16" Diameter up to 4 ft. ³ Capacity
Iron Filter	6" - 16" Diameter
Sediment Filter	6" - 16" Diameter
Carbon Filter	6" - 16" Diameter
Neutralizing Filter	6" - 16" Diameter
Additional Information	
Electrical Rating	12 VDC
Pressure	Hydrostatic: 300 psi Working: 20 - 125 psi
Temperature	34 ° - 110 ° F

*Noryl is a registered trademark of General Electric Company

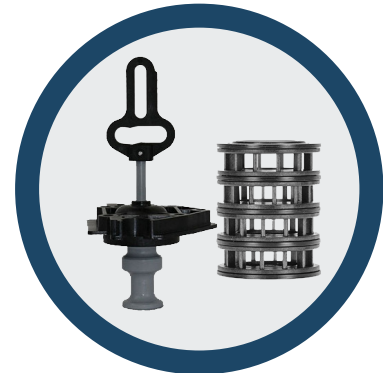

Legacy View Control

When you download the Legacy View app and open it, you will see a screen similar to this one. Any Legacy View bluetooth compatible device will appear here as long as it is within range and you have bluetooth enabled on your phone or tablet. Simply click on your device to get started.

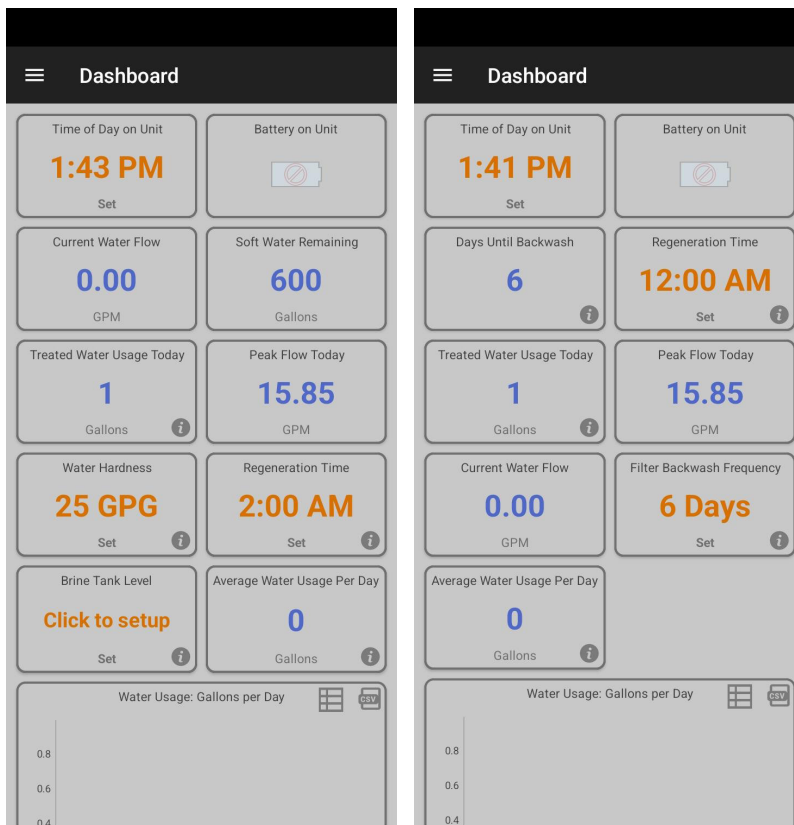
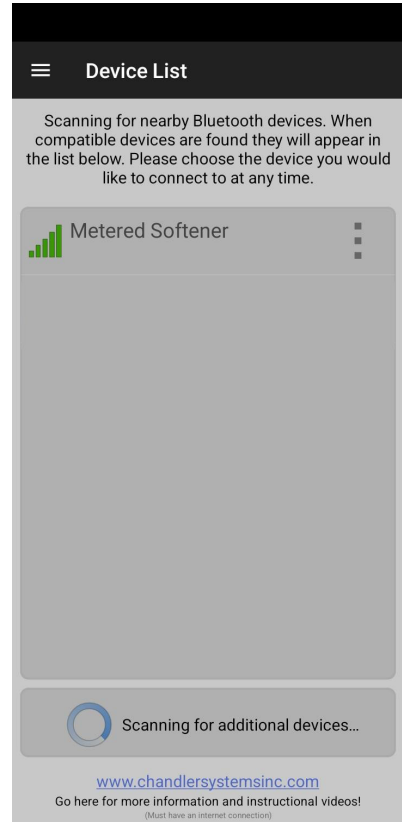

After selecting your system, you will be greeted with one of the follow Dashboards (depending on Softener or Filter). To begin, adjust the settings in **ORANGE** by tapping on the box. The systems come preset here and the default settings should be fine for most applications.

Legacy View Control

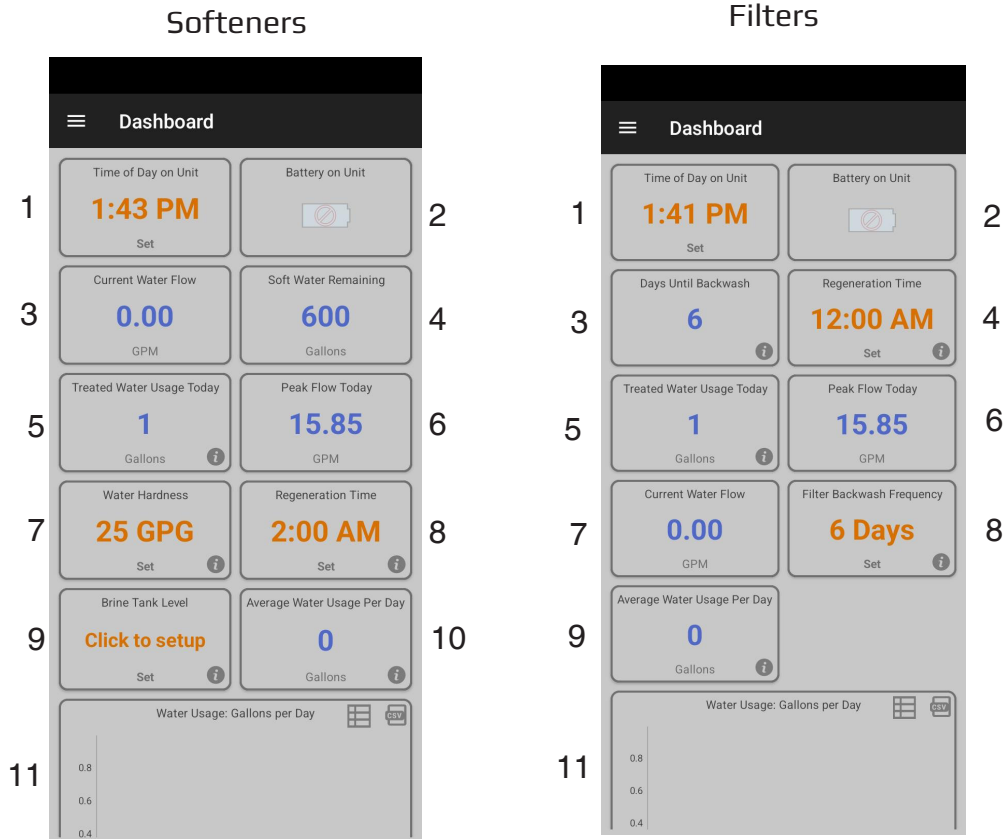

1. Current time on the system. Tap the box to set the time to that of the devices
2. Shows battery life of attached 9v backup battery
3.
 - a. Softeners: Shows current water flow
 - b. Filters: Days until next regeneration
4.
 - a. Softeners: Amount of soft water remaining
 - b. Filters: The time the system regenerates
5. Amount of water used that day
6. Highest GPM read that day
7.
 - a. Softeners: Water hardness that can be adjusted by tapping on the box
 - b. Filters: Current GPM of water being used
8.
 - a. Softeners: When the system regenerates
 - b. Filters: Amount of days between regenerations
9.
 - a. Softeners: Allows the user to view a simulated version of their salt levels in order to know when to refill their brine tank without being near the system
 - b. Filters: Amount of water used on average
10. Amount of water used on average
11. A graph of water usage for a whole month

Advanced Settings

The Advance Settings page is where cycle times and certain other settings can be adjusted. To get there simply click on the **three lines** in the top left hand corner to bring up the side menu and just tap on the **Advance Settings** button. Only change these settings if instructed by Chandler Systems or a Registered Plumber.

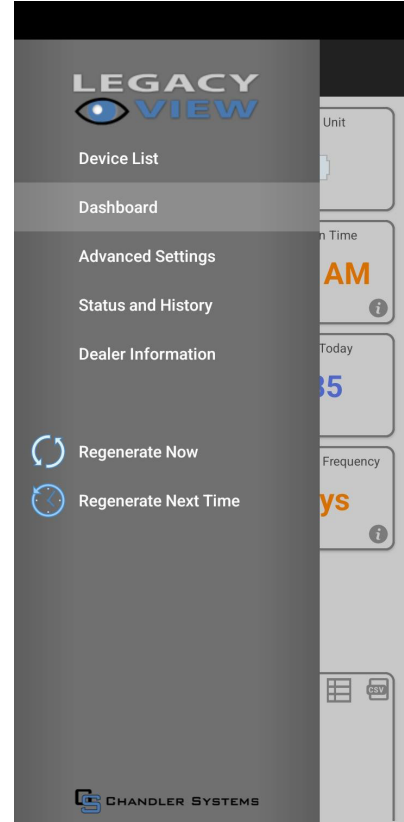
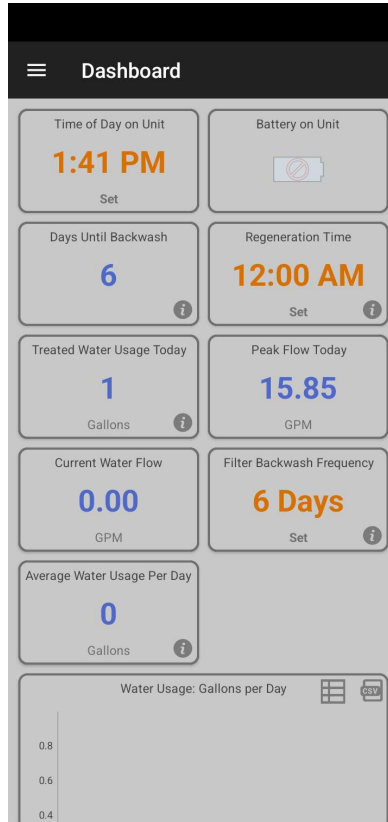

Advanced Settings - Softener

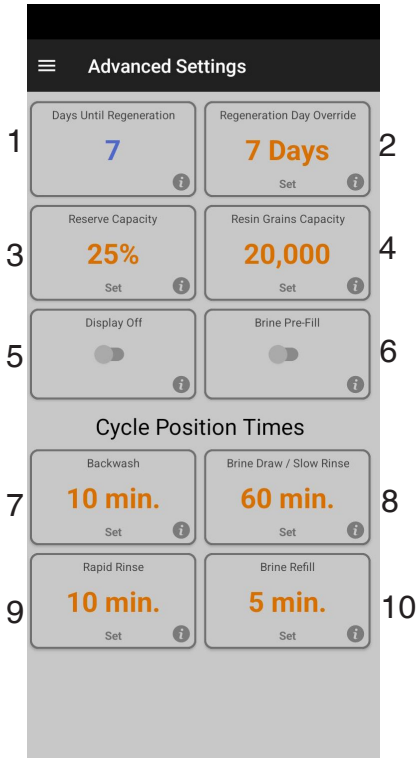

1. Days left until next regeneration based on Regeneration Day Override
2. Amount of days between regeneration can set between 0-29. Setting at 0 turns this feature off
3. Percentage of soft water saved in case system runs out before next regeneration time
4. Capacity of system based on size of tank. This is preset at factory and should never need to be adjusted.
5. Turns the display off until a button is pressed
6. Turning this on adjust the cycles to have the forth regeneration step happen 2-3 hours prior to fill the brine tank. This keeps the brine tank dry until a regeneration is needed.
7. An upflow cycle to clean the media bed
8. Draws in salty water from the brine tank and rinses it over the media bed to rejuvenate the resin
9. A downflow cycle to re-compact the media bed
10. Fills the brine tank with water for the next regeneration

Advanced Settings - Aeration Filter

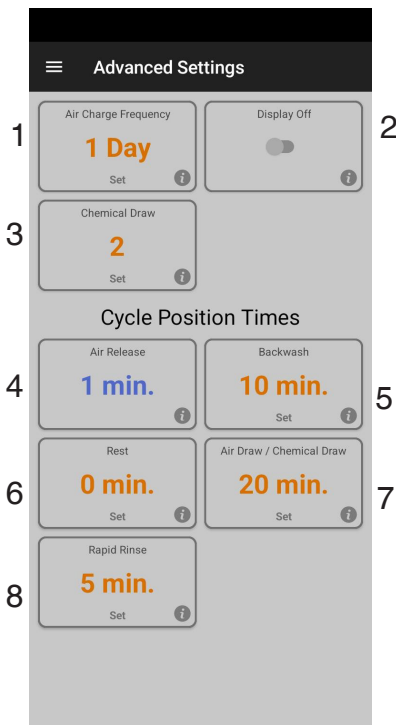

1. How often the system adds air to the water
2. Turns the display off until a button is pressed
3. How much the system draws a chemical if the system is setup for that feature.
4. Non-Adjustable step for purging air out of the system
5. An upflow cycle to clean the media bed
6. A rest period only if needed to allow the well to refill before next steps
7. Draws air and/or chemical into the media bed to oxidize and remove any contaminants
8. A downflow cycle to re-compact the media bed

NOTE: A normal backwashing filter only has boxes 2, 5, 6, and 8 on its Advance Settings Page

Status and History

The Status and History page under the side menu gives a more detailed account of how much water is actually being used.

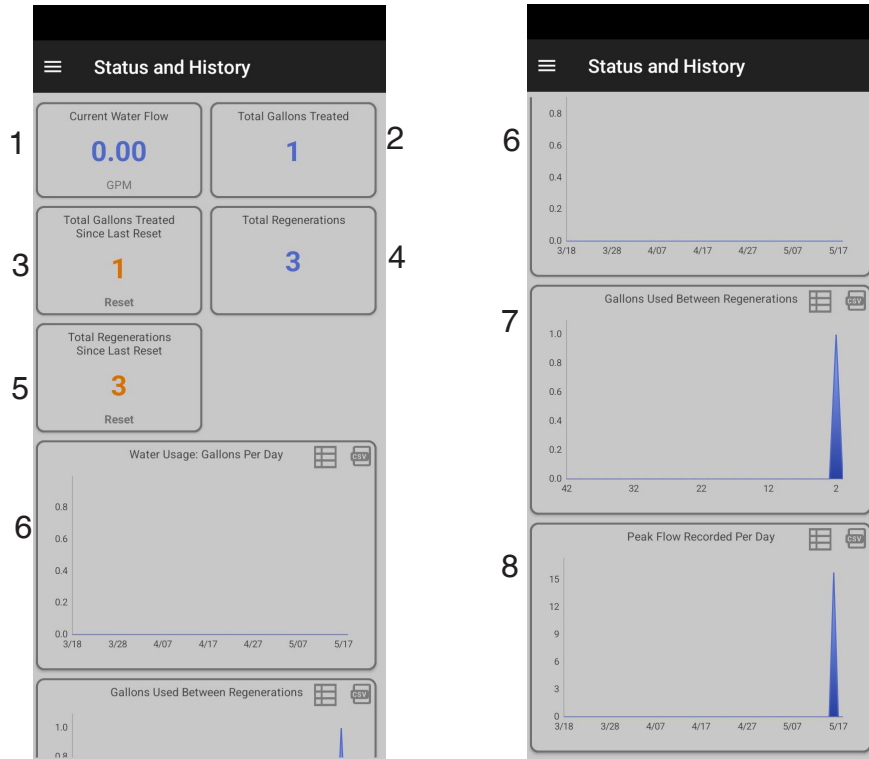

1. Amount of water flowing through system currently
2. Total gallons treated since system was installed
3. Amount of water that has gone through system since last regeneration
4. Total number of regenerations since system was installed
5. Number of regenerations since the system last lost power
6. Number of gallons used everyday
7. Total number of gallons used between each regeneration
8. Highest recorded gpm value per day

The recent release of Legacy View, version 3.1.18, adds Salt Monitoring to the existing generation of residential and commercial metered softeners that are running the **C4.22 firmware**. Below is an overview of the new functionality.

General Setup and Use

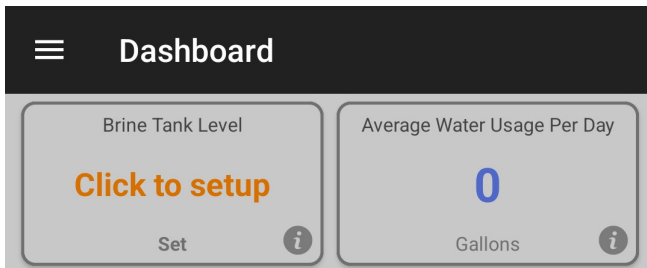

When you first connect to your metered softener you will see a new item on the dashboard called, **“Brine Tank Level”** and it will display **“Click to Setup”** to indicate that initial configuration is required.

Once you tap **“Click to setup”** or **“Set”**, the initial configuration will be shown. The initial configuration consists of brine tank width and the max fill height of the salt. For residential metered softeners, this will default to a brine tank width of 16 inches and a max fill height of 24 inches.

For commercial metered softeners, this will default to a brine tank width of 18 inches and a max fill height of 31 inches. Note that the commercial brine tanks will also include the 24 inch and 30 inch brine tank option.

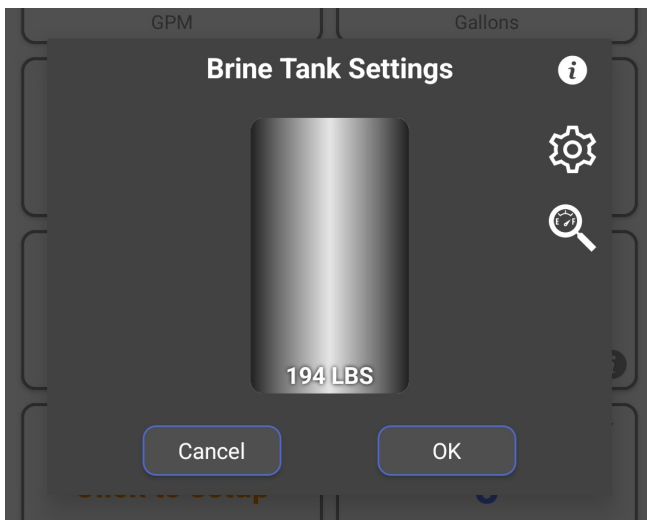
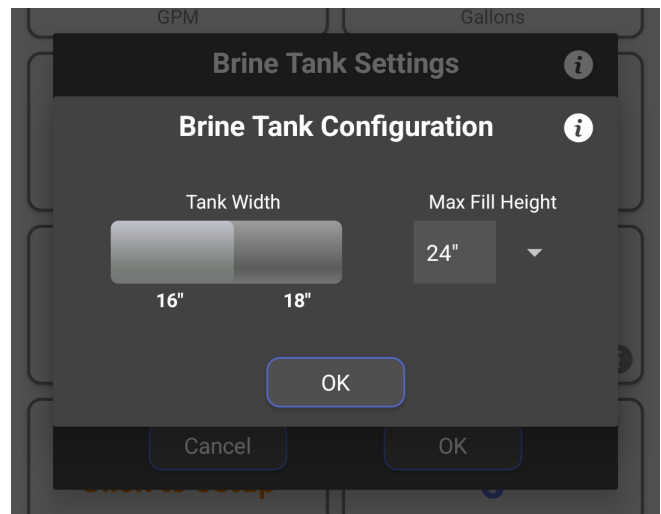

Once the initial configuration is complete you can enter the current salt level in the tank by either tapping the brine tank or sliding up and down to the desired position. This will need updated every time you add salt to your brine tank. You can also adjust the initial configuration by tapping the gear icon and you can also configure the salt monitoring by clicking the magnifying glass icon (specific instructions about this later in the **“Salt Monitoring”** section).

LEGACY VIEW

When the salt level is set the brine tank level on the dashboard will update to show a smaller representation of the brine tank with the current salt level. When the softener completes a regeneration the salt level will be updated accordingly. Please note that the value may be lower than what was shown when entering the salt level. This is expected behavior as it rounds down to the pounds of salt remaining that can complete full regenerations to help avoid hard water from breaking through.

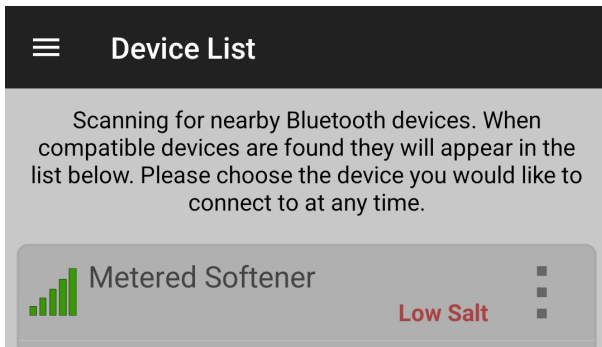
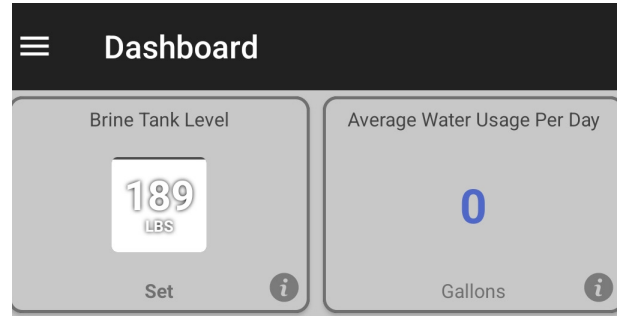

When a valve reports it has low salt it can be seen on the device list when you initially open the app. This happens when the salt level in the brine tank is determined to be at 20% or less.

Salt Monitoring

For users that would like to see the overall salt level status, for one or more metered softeners, without having to connect to each valve then we also offer that functionality as well. The setup and functionality work a little differently in Android and iOS so both methods will be shown to illustrate this. However, they will both do a quick scan every 30 minutes for nearby metered softeners. If a metered softener is found, then it will check to see if that softener was included in the monitoring. If it was included, then the status is checked and reported.

Android Salt Monitoring

You can enable the salt monitoring service by tapping the magnifying glass icon from the brine tank settings dialog. Tapping the icon will open the salt monitor configuration dialog. Tapping the button under the **“Enable Monitoring”** option toggles the monitoring on or off. Once enabled, it will be enabled for all valves. However, you must indicate what valves you would like to monitor. Enabling the salt monitoring will also automatically include the softener you’re connected to. You can decide whether to include a valve by toggling the option under **“Include Softener”**. This must be done for each valve you want to monitor.

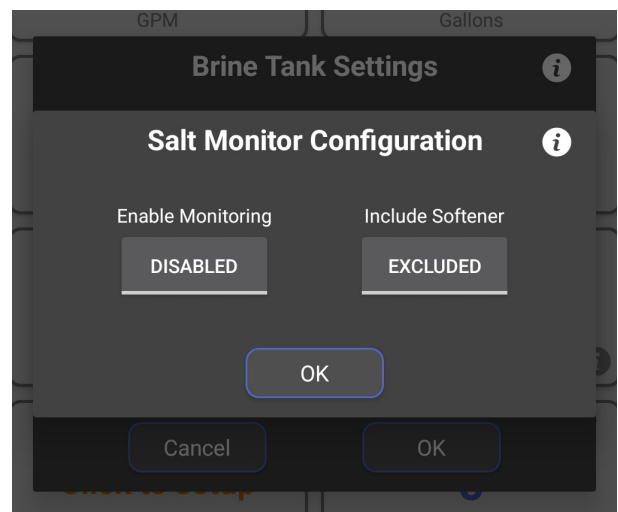

LEGACY VIEW

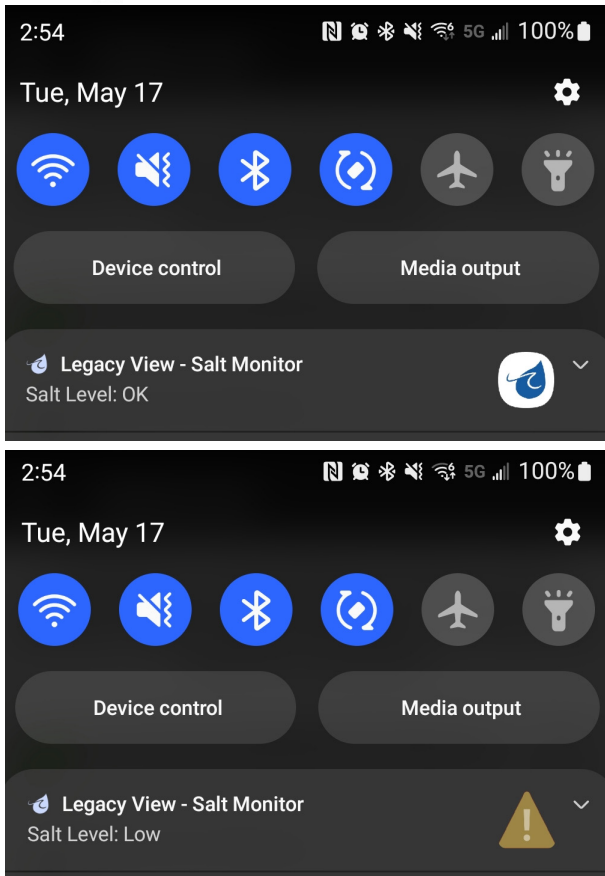

Once enabled, a notification is created that can't be dismissed until you disable the salt monitoring. This notification is a service that runs in the background and will trigger a Bluetooth scan every 30 minutes, as mentioned above. If all softeners are reporting as having adequate salt levels, then it will display **"Salt Level: OK"**. If a softener is reporting that it has low salt, then **"Salt Level: Low"** will be displayed with a warning symbol. Once you add more salt to your brine tank and adjust the level in the app it will report adequate again. Note that you can update the notification manually by opening the app. The app will communicate the scan results in real-time to the notification. Tapping this notification will also open the app.

Note:

If no softeners have been included, then **"No Softeners Detected"** will be displayed. This will also be displayed during initial setup as Bluetooth devices do not advertise when you're connected to them. However, once monitoring is enabled and a softener is included to be monitored, then the notification will update once the device list is loaded again and show correctly. Also, if the softener(s) being monitored is not in Bluetooth range during the last scheduled scan, the notification will say **"No Softeners Detected"**.

iOS Salt Monitoring

iOS uses a widget to monitor the salt level and can be used on any device running iOS 14 or later. The widget can be setup using the following steps:

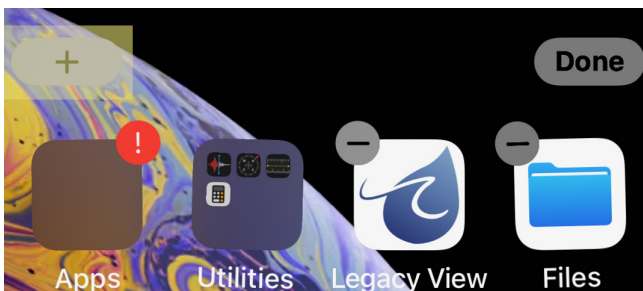

From the Home Screen, touch and hold a widget or an empty area until the apps start to jiggle. Once the apps are jiggling, press the gray + button in the upper left-hand corner.

LEGACY VIEW

Scroll down until you see Legacy View and tap that to select it.

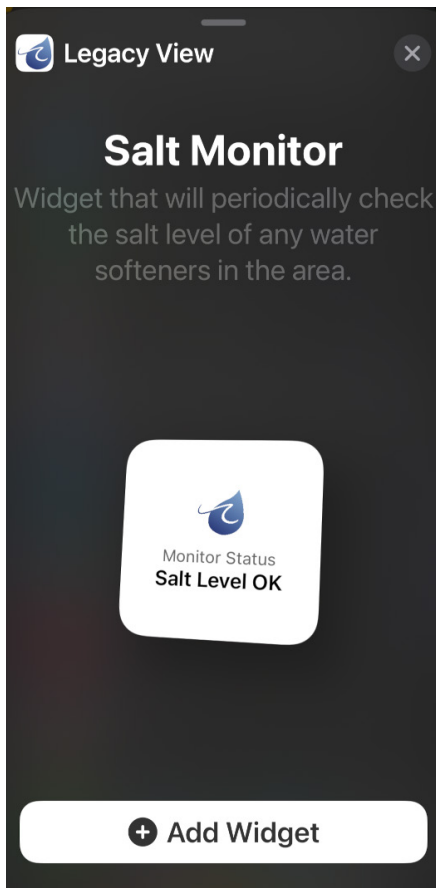
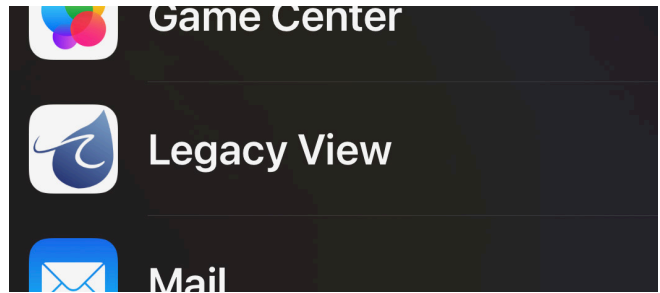

From here, you can click and drag the widget to the home screen or click the "Add Widget" button. This will place it on the home screen, and it will initiate an initial scan.

Once the widget is on the home screen, you can either tap any empty space or tap the "Done" button.

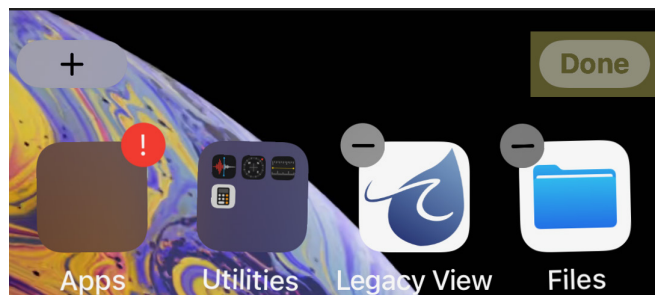

LEGACY VIEW

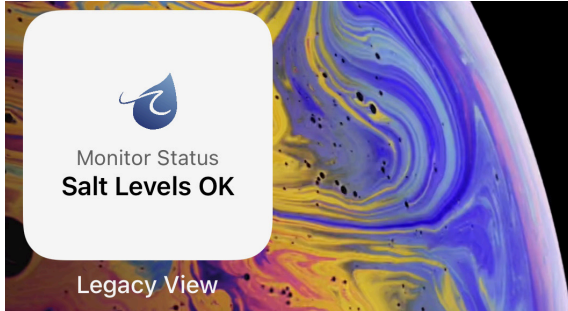

Once setup, the widget will trigger a Bluetooth scan every 30 minutes, as mentioned above. If all softeners are reporting as having adequate salt levels, then it will display "Salt Level OK". If a softener is reporting that it has low salt, then "Salt Level Low" will be displayed. Once you add more salt to your brine tank and adjust the level in the app it will report adequate again. Tapping this widget will also open the app.

Now that the widget is setup, you can configure the salt monitoring within the app by tapping the magnifying glass icon from the brine tank settings dialog. Tapping the icon will open the salt monitor configuration dialog. Tapping the button under the "Enable Monitoring" will explain the steps to setup the widget. You can decide whether to include a valve by toggling the option under "Include Softener". This must be done for each valve you want to monitor.

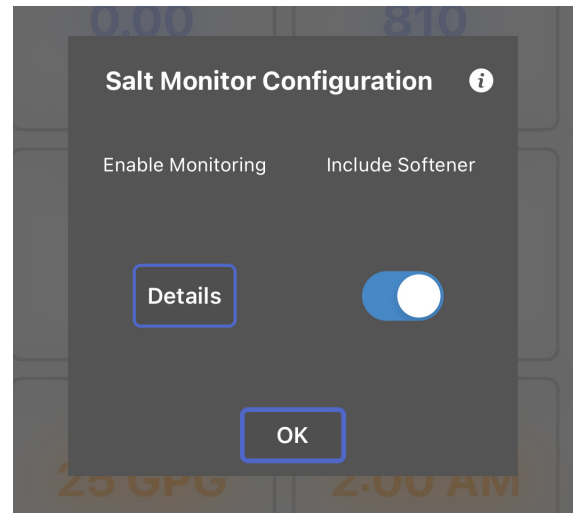

Note:

If no softeners have been included, then "No Softeners Detected" will be displayed. However, once you have enabled monitoring and included the softener to be monitored, then it will update when the next scan occurs. Also, if the softener being monitored is not in Bluetooth range during the last scheduled scan, the widget will say "No Softeners Detected".

Troubleshooting

If the salt level in the tank is not tracking with the salt level reported in the app, then there is most likely a problem with their brining system. If there is more salt than expected, then the softener is probably not filling the brine tank properly. This could be the screen under the injector cover is plugged or the brine line flow control is fouled. It could also not be properly drawing the water out of the brine tank, but this would probably be indicated by an unusually high-water level in the brine tank. The injector could also need cleaned. If there is less salt than expected, then the softener is over filling. In this case, the brine valve could be leaking, or the brine line flow control is damaged or missing.

Main Menu / Button Control

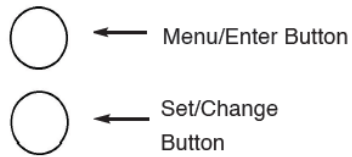

1. To enter main menu press the **Menu/Enter** button
(Time of Day will Flash)
2. To set time of day press the **Set/Change** button
(First digit will begin to flash)

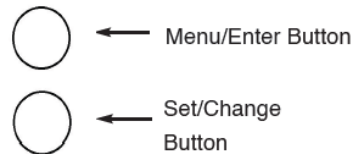

- To change digit value press the **Set/Change** button multiple times and then press the **Menu** button to adjust the next digit
- (Next digit will flash)
- (Once hours is accepted all digits will flash)

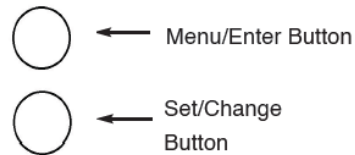
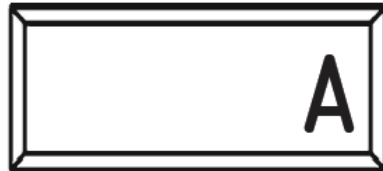

3. With all digits flashing press the **Menu** button to set A.M. or P.M.
- To change digit value press the **Set/Change** Button until it is correct
 - To accept the digit press the **Menu/Enter** Button
 - (Once A.M./P.M. is accepted the next **Menu/Enter** item will flash)

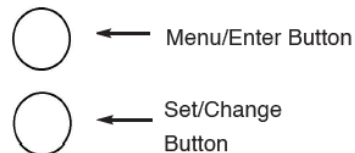

4. **(Metered Version)** Setting The Hardness
- To change digit value press the **Set/Change** button multiple times and then press the **Menu** button to adjust the next digit
 - Once the Last Digit is Accepted all Digits will Flash
- Note: One cycle must be completed before new setting will be accepted.**

Main Menu



5. **(Filter Version)** Set the Regeneration Frequency
- To change digit value press the **Set/Change** button multiple times and then press the **Menu Button** to adjust the next digit
 - Once the last digit is accepted all digits will flash
- Notes: -Maximum Value is 29
-If value is Set to 0, automatic regeneration will never occur
-Note: One cycle must be completed before new setting will be accepted.



6. **(Aeration Version)** Set the Air Recharge Frequency
- To change digit value press the **Set/Change** button multiple times and then press the **Menu** button to adjust the next digit
 - Once the last digit is accepted all digits will flash
 - If value is set to 0, automatic regeneration will only occur with a regeneration
- Note: One cycle must be completed before new setting will be accepted.**

7. To Exit menu press the **Menu/Enter** Button

Note: If no buttons are pressed for 60 seconds or longer the menu will automatically be exited.

Normal Operation

1. (Metered Version)

-Normal Display Alternates Between Time of Day and Gallons of Treated Water Remaining.

-When the display is Showing Gallons Remaining and there is Water Flow the Upper Colon Lights will Flash.

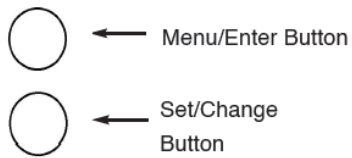
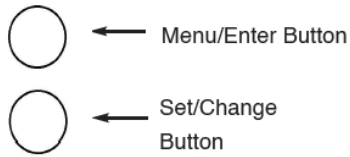
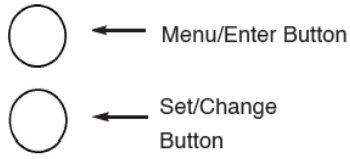

-As Treated Water is Used the Gallons Remaining Display will Count Down from a Maximum Value to 0.

-Once the Count Reaches 0 a Regeneration Cycle will be Initiated at the Next Designated Regeneration Time.

2. (Filter/Aeration Version)

-Normal Display Alternates Between Time of Day and Days Until Regeneration.

-Days Remaining Until the Next Regeneration will Count Down from the Regeneration Day Override Value to 1 Day Remaining.

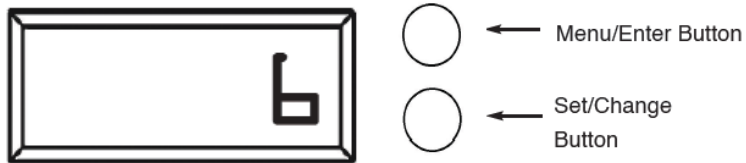
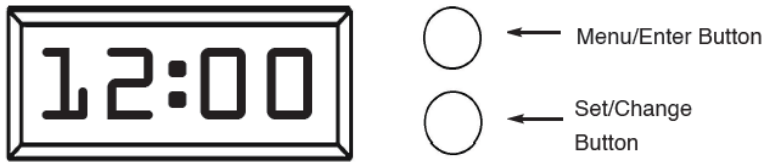

-Once the Count Reaches 1 a Regeneration is Initiated at the Next Designated Regeneration Time.

Normal Operation



1. Battery Back-Up (This unit uses a standard 9 volt alkaline battery)
 - Installing the battery
 - The control valves have a battery wire that hangs down from the control board into the battery tray
 - From there, let the battery just sit in the tray
- Features of battery back-up
 - Maintains the time of day during power failures.
 - The battery back-up continues to count down gallons remaining during power failure (Metered Version)

Note: During power failure to conserve battery power the display is turned off. However, to confirm that the battery is working you can press either button and the display will turn on for five seconds.

* Menus can not be accessed during power failure

* If a power failure occurs while the valve is in regeneration the valve will cycle to a bypass position and will resume the regeneration when power is restored.

Starting Extra Regeneration Cycles

1. Starting Delayed Extra Cycle

-(Metered Version)

- If gallons remaining is not already at 0 Press and Hold the **Set/Change** Button
- After 3 seconds the gallons remaining display will read 0 Example [0000]
- Regeneration cycle will be initiated at the next designated regeneration time

-(Filter/Aeration Version)

- If days remaining is not already at 1 press and hold the **Set/Change** Button.
- After 3 seconds the days remaining display will read 1
- Regeneration cycle will be Initiated at the next designated regeneration time

2. Starting Immediate Extra Cycle - First, Complete Above Delayed Cycle Steps

-(Metered Version)

- With gallons remaining at 0, press and hold the **Set/Change** button
- After 3 seconds the regeneration cycle will begin

-(Filter Version)

- With days remaining at 1 press and hold the **Set/Change** button
- After 3 seconds the regeneration cycle will begin.

3. Fast Cycling Thru Regeneration

- First complete above immediate cycle steps
- Press and hold the **Set/Change** button
- After 3 seconds the valve will start to advance to the next step

Master Programming Mode

Entering Master Programming Mode

-To Enter Master Programming Mode Press and Hold both buttons for 5 seconds.

Note: All Master Programming functions have been preset at the factory. Unless a change is desired it is NOT necessary to enter the Master Programming Mode.

THIS IS EASIER TO DO ON THE LEGACY VIEW APP

Regeneration Time (r)

After pressing the **Menu/Enter** and **Set/Change** Button, the display shows the option setting for Regeneration Time. It is identified by the letter 'r' in the left digit. Set the desired time of day that a regeneration may occur, if required. The first digit(s) indicates the Hour and the other digit indicates A.M. or P.M.. Example: 2 A.M. regeneration time - [r 2A] (Factory Setting for Softeners)

To adjust this value press the **Set/Change** button.

To accept the digit value press the **Menu/Enter** button.



Regeneration Day Override

Press **Menu/Enter** Button. This display is used to set the maximum amount of time (in days) the unit can be in service without a regeneration. This option setting is identified by the letter 'A' in the left digit. Regeneration will begin at the set Regeneration Time. A 0 setting will cancel this feature. The Max Value for this item is 29.

Example: Override every 7 days - [A - 07] (Factory Setting)

Cancel setting - [A - 00]

To adjust this value press the **Set/Change** button.

To accept the digit value press the **Menu/Enter** button.



Regeneration Cycle Step Programming

Press the **Menu/Enter** Button. The next 4 displays viewed are part of a series of option settings used to program the Regeneration Cycle. Each display is used to set the duration time in minutes for that specific step in a regeneration cycle. A step # will turn on for the regeneration cycle step being programmed. Regeneration steps are skipped by setting the display to 0.

Examples: Regeneration Cycle Step #1 - 10 minutes - [1 - 10] (Factory Setting)
 Regeneration Cycle Step #2 - skipped - [2 -- 0]

Desired lbs. salt ÷ 3 ÷ (Brine Line Flow Control) size (gpm) = refill time in minutes
 12 lbs. salt ÷ 3 ÷ .50 = 8 minute refill

* All units are preprogrammed for full salting at factory

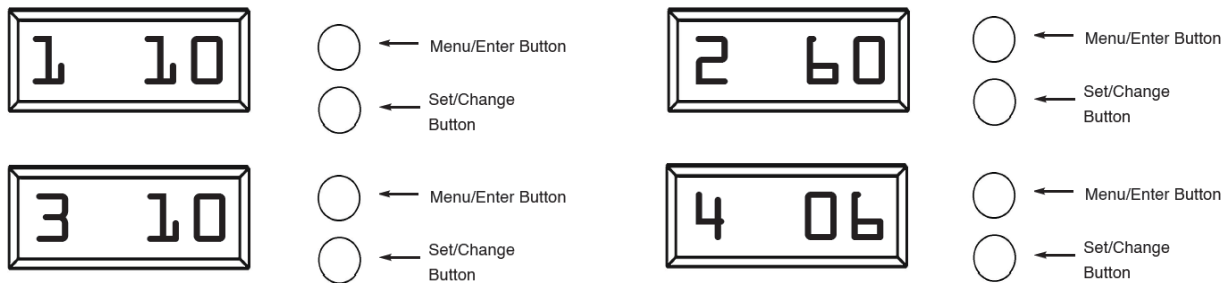

System Capacity in Grains (c)

Press the **Menu/Enter** button. This display is used to set the system capacity in grains and is used in conjunction with the hardness setting to calculate total gallons of treated water available between regenerations. The maximum value for this item is 399.

Example: 32,000 grain capacity [c 0 3 2]

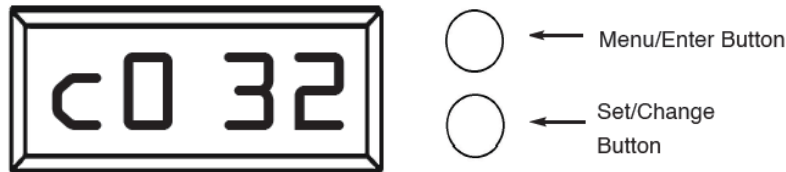

System Reserve Capacity in % (P)

Press the **Menu/Enter** button. This display is used to set the system reserve capacity in percent and is used in conjunction with the hardness and capacity setting to calculate total gallons of treated water available between regenerations. This setting gives a buffer of treated water in case the system runs out of soft water hours before the next regeneration time

Example: 25% [P 2 5]



Bluetooth Capability (bE 1)

Press the **Menu/Enter** button. This display is used to turn the bluetooth capabilities of the system on (1) or off (0). The system should always be on regardless of it's usage. If a connection to system cannot be made, verify this setting is turned on.

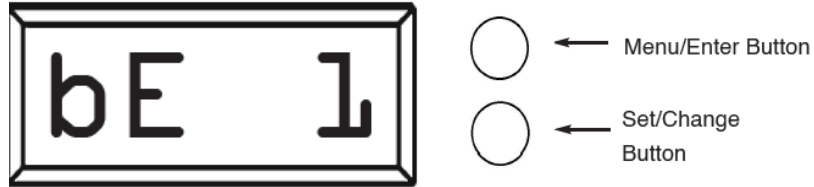

Bluetooth Password (btPP)

Press the **Menu/Enter** Button. The next display shown is the Bluetooth Password (btPP). When shown, this number will flash between "btPP" and a four digit code. The code is used for accessing the Legacy View app. The default is "1234" and unless it has been changed, no password will be needed to access the control valve with Legacy View.



Brine Pre-Fill (PE 0)

Press the **Menu/Enter** button. The next display shown is the Brine PreFill feature (P E 0). This is defaulted to off (0) but can be turned on by pressing the **Set/Change** button twice to turn it on (1).

Activating this feature will turn the brine pre-fill on which fills the brine tank 2 hours before the regeneration instead of as the last step of a regeneration cycle.

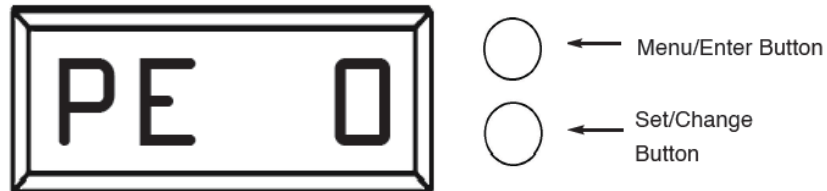

Display Off (do 0)

Press the **Menu/Enter** button. The next display shown is the **Display Off** feature (d o 0). This is defaulted to off (0) but can be turned on by pressing the **Set/Change** button twice to turn it on (1)

Activating this feature will turn the display off when not in use. This does not shut the system off, just what is shown to the user at a quick glance.

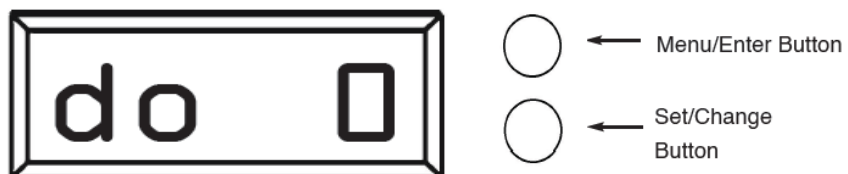

Filter Master Programming

Regeneration Time (r)

After pressing the **Menu/Enter** and **Set/Change** button, the display shows the option setting for Regeneration Time. It is identified by the letter 'r' in the left digit. Set the desired time of day that a regeneration may occur, if required. The first digit(s) indicates the Hour and the other digit indicates A.M. or P.M..

Example: 12 A.M. regeneration time - [r12A] (Factory Setting for Filters)

To Adjust this Value Press the Set/Change Button.

To Accept the Digit Value Press the Menu/Enter Button.



Regeneration Cycle Step Programming

Press the Menu/Enter Button. The next 3 displays viewed are part of a series of option settings used to program the Regeneration Cycle. Each display is used to set the duration time in minutes for that specific step in a regeneration cycle. A step # will turn on for the regeneration cycle step being programmed. Regeneration steps are skipped by setting the display to 0.

Examples: Regeneration Cycle Step #1 - 10 minutes - [1 - 10] (Factory Setting)

Regeneration Cycle Step #2 - skipped - [2 - - 0]

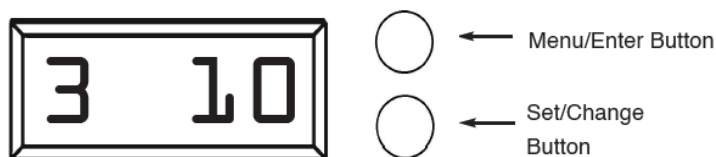
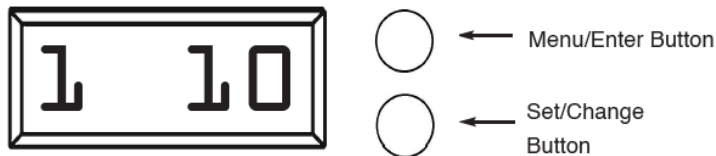

Bluetooth Capability (bE 1)

Press the **Menu/Enter** Button. This display is used to turn the bluetooth capabilities of the system on (1) or off (0). The system should always be on regardless of it's usage. If a connection to system cannot be made, verify this setting is turned on.

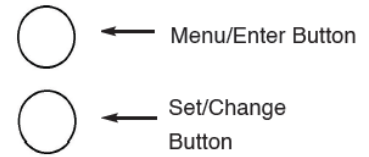

Bluetooth Password (btPP)

Press the **Menu/Enter** Button. The next display shown is the Bluetooth Password (btPP). When shown, this number will flash between "btPP" and a four digit code. The code is used for accessing the Legacy View app. The default is "1234" and unless it has been changed, no password will be needed to access the control valve with Legacy View.

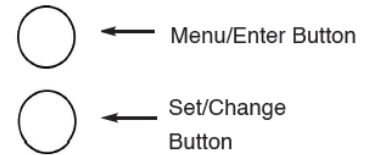

Display Off (do 0)

Press the **Menu/Enter** button. The next display shown is the Display Off feature (d o 0). This is defaulted to off (0) but can be turned on by pressing the **Set/Change** button twice to turn it on (1)

Activating this feature will turn the display off when not in use. This does not shut the system off, just what is shown to the user at a quick glance.

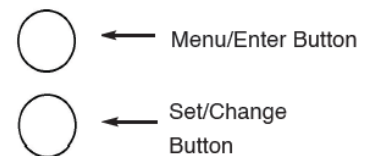

Aeration Filter Master Programming

Regeneration Time (r)

After pressing the Menu/Enter and Set/Change Button, the display shows the option setting for Regeneration Time. It is identified by the letter 'r' in the left digit. Set the desired time of day that a regeneration may occur, if required. The first digit(s) indicates the Hour and the other digit indicates A.M. or P.M..

Example: 12 A.M. regeneration time - [r12A] (Factory Setting for Filters)
 To Adjust this Value Press the Set/Change Button.
 To Accept the Digit Value Press the Menu/Enter Button.



Regeneration Cycle Step Programming

Press the **Menu/Enter** Button. The next 4 displays viewed are part of a series of option settings used to program the Regeneration Cycle. Each display is used to set the duration time in minutes for that specific step in a regeneration cycle. A step # will turn on for the regeneration cycle step being programmed.

Regeneration steps are **skipped** by setting the display to 0.

For aeration units, the first regeneration step will not appear as it is not adjustable.

Examples: Regeneration Cycle Step #2 - 10 minutes - [2 - 10] (Factory Setting)
 Regeneration Cycle Step #3 - skipped - [3 - - 0]

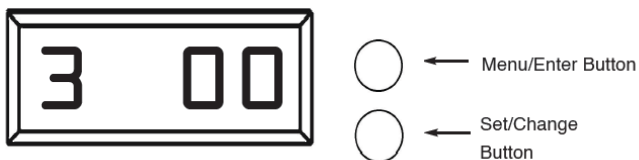

Pulse Chlorine Setting (J 02) - Side Mount Aeration Valve Only

Press the Menu/Enter Button. This display shows how much chlorine will be injected into the system if the system is designed for it. This is mainly used for Side Aeration valves.

The pulse chlorine setting adjusts how many times and how much chlorine is injected into the system during the Air Replenish / Oxyclean NP Injection cycle (Step 4). The table below indicates the approximate amount of chlorine solution that will be injected for the different settings.



Pulse Chlorine Setting	Approx. Total Amount of Chlorine	Description
0	0 oz.	Oxyclean option is off, no chlorine will be injected.
1	8 oz.	Chlorine will be injected in 1 pulse at the beginning of the cycle step.
2	10 oz.	Chlorine will be injected in 2 pulses, at the beginning of each ½ of the cycle step.
3	12 oz.	Chlorine will be injected in 3 pulses, at the beginning of each 1/3 of the cycle step.
4	16 oz.	Chlorine will be injected in 4 pulses, at the beginning of each 1/4 of the cycle step.

Bluetooth Capability (bE 1)

Press the **Menu/Enter** Button. This display is used to turn the bluetooth capabilities of the system on (1) or off (0). The system should always be on regardless of it's usage. If a connection to system cannot be made, verify this setting is turned on.

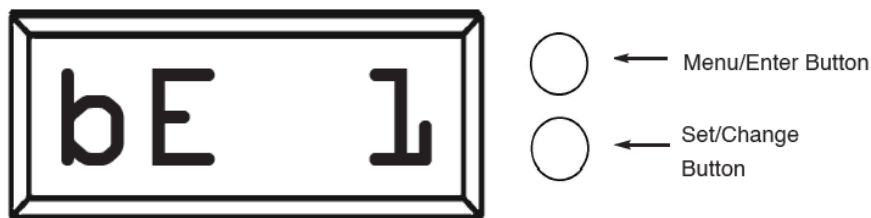

Bluetooth Password (btPP)

Press the **Menu/Enter** Button. The Next display shown is the Bluetooth Password (btPP). When shown, this number will flash between “btPP” and a four digit code.

The code is used for accessing the Legacy View app. The default is “1234” and unless it has been changed, no password will be needed to access the control valve with Legacy View.



Display Off (do 0)

Press the **Menu/Enter Button**. The next display shown is the Display Off feature (d o 0). This is defaulted to off (0) but can be turned on by pressing the Set/Change button twice to turn it on (1)

Activating this feature will turn the display off when not in use. This does not shut the system off, just what is shown to the user at a quick glance.



CABINET SOFTENER POWER HEAD ASSEMBLY

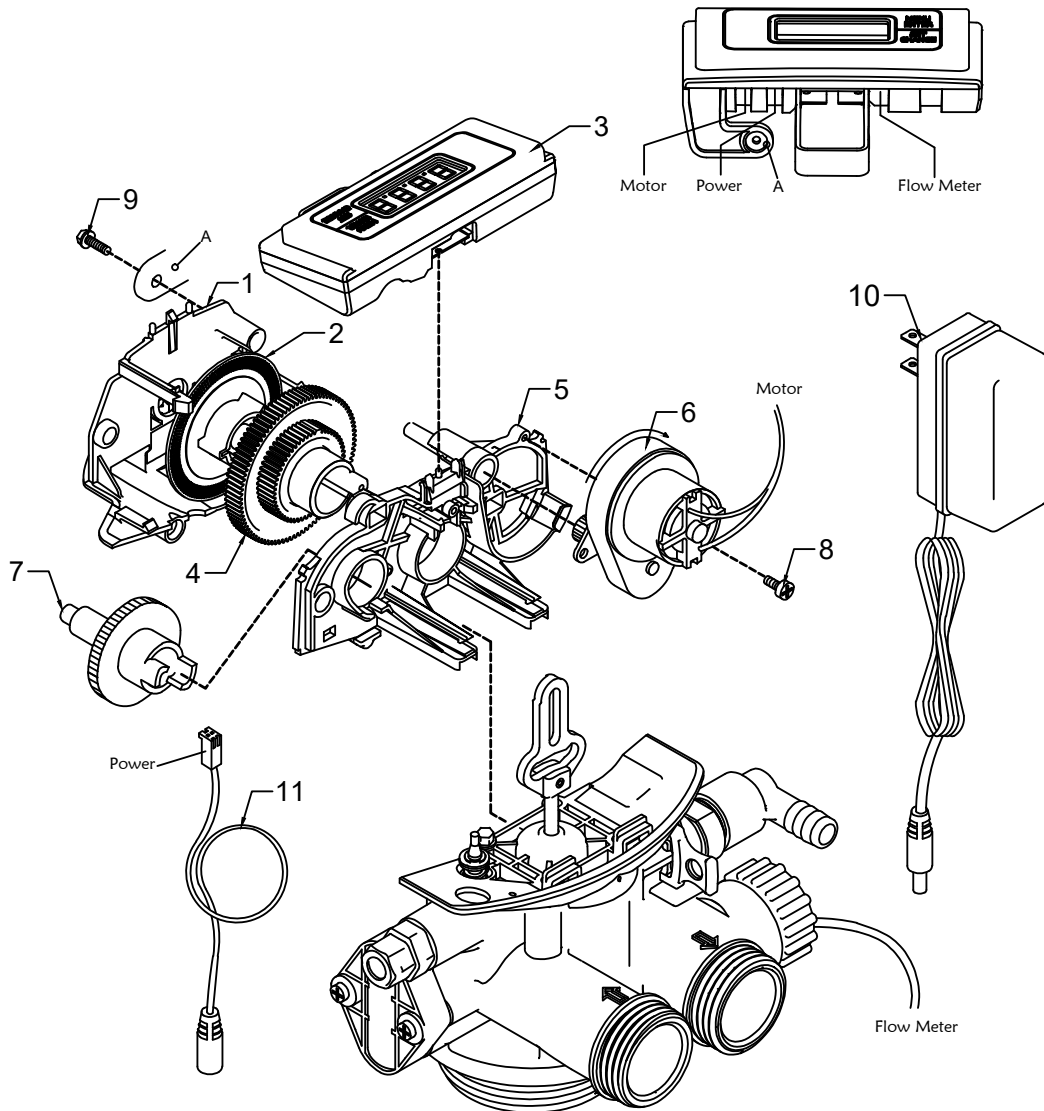

REF	DESCRIPTION	PART NO	QTY
1	Front Plate	20016X001	1
2	Encoder Wheel	20001X007	1
3	Cabinet Legacy Board Assembly	20016X101	1
4	Main Gear	21001X120	1
5	Back Plate	20016X002	1
6	Motor Assy.	20016X006	1
7	Brine Cam	20001X122	1
8	SC2	SC2, Motor Screw	1
9	SC10	SC10 Screw	1
10	12V Power Supply	20001X125	1
11	Power Cord	MTR-CORD-BT	1

CABINET SOFTENER BODY ASSEMBLY

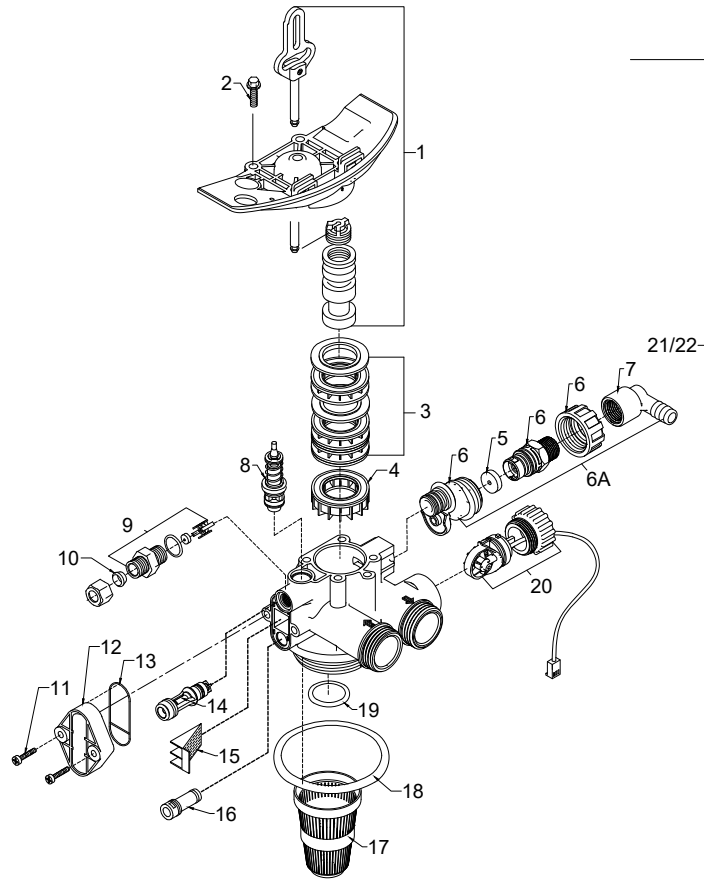

REF	DESCRIPTION	PART NO	QTY
1	Piston Assembly	20001X231	1
2	Screw	20001X001	2
3	Seal & Spacer Kit	20561X253	1
4	Bottom Spacer	20001X234	1
5	DLFC Button 2.0	20251X267	1
6A	Flow Control Housing	20017X251	1
7	Drain Elbow	20017X266	1
8	Brine Valve	20561X225	1
9	BLFC Assy	20001X228	1
10	Brine Line Ferrule	20251X305	1

REF	DESCRIPTION	PART NO	QTY
11	Injector Cap Screw	20001X226	2
12	Injector Cap	20001X223	1
13	Injector Seal	20001X224	1
14	Injector - White	20017X219	1
15	Screen	20001X222	1
16	Plug	20001X217	1
17	Basket	33000X003	1
18	Valve O-Ring	20015X043	1
19	Dist. O-Ring	20561X204	1
20	Meter Assy	20017X203	1

SOFTENER VALVE

REF	DESCRIPTION	PART NO.	QTY
1	Piston Assembly	20001X231	1
2	10-24 X 3/4" Screw SST	20001X001	3
3	Seal and Spacer Kit	20561X253	1
4	End Spacer	20001X234	1
5	Flow Control Button 1.5 GPM	20251X266	1
	Flow Control Button 2.0 GPM	20251X267	1
	Flow Control Button 2.4 GPM	20251X268	1
6A	DLFC Assy.	20017X251	1
7	90 Degree Hose Barb Elbow	20017X266	1
8	Brine Valve	20561X225	1
9	BLFC Assembly	20001X228	1
10	BLFC Ferrule 3/8"	20251X305	1
11	10-24 X 3/4" Screw SST	20001X001	2
12	Injector Cap	20001X223	1
13	Injector Cap Seal	20001X224	1
14	Injector, White	20017x219	1
	Injector, Blue	20017x220	1
15	Injection Screen	20001X222	1
16	Plug	20001X217	1
17	Tank. O-Ring	20015X043	1
18	Dist. O-Ring	20561X204	1
19	Meter Assembly	20017X203	

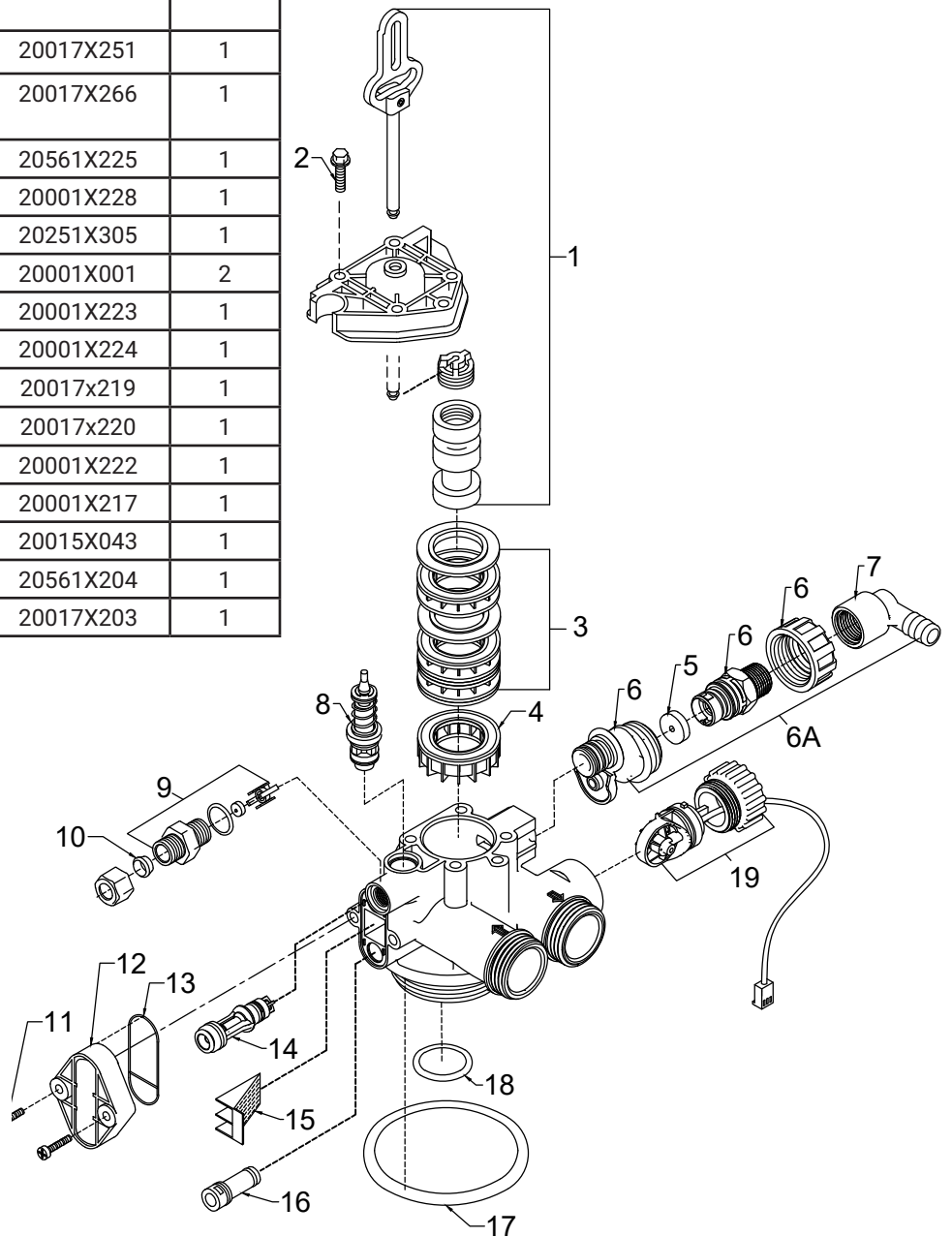

SOFTENER POWERHEAD

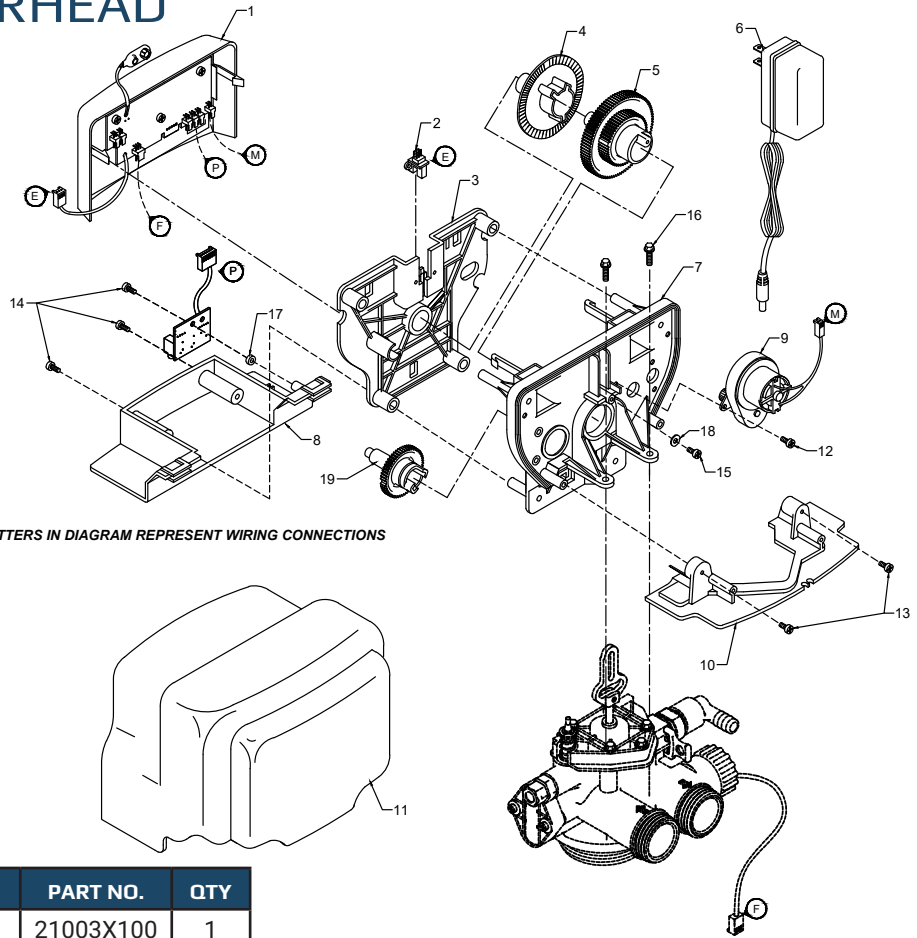

REF	DESCRIPTION	PART NO.	QTY
0	Metered Power Head Assy.	21003X100	1
1	Softener Circuit Board Assy.	22003X102	1
2	Encoder	20001X124	1
3	Front Plate	20001X004	1
4	Encoder Wheel	20001X007	1
5	Main Gear	21001X120	1
6	Power Supply	20001X125	1
7	Back Plate	20001X005	1
8	Lower Front Base For Cover	20111X002	1
9	Legacy View Motor Assy.	20016X006	1
10	Lower Back Base for Cover	20111X003	1
11	Valve Cover	20111X017	1
12	6 X 1/2" Slotted, Hex Head	20001X003	1
13	6 X 1/2" Phillips, Pan Head	SC10	3
14	6 X 1/2" Slotted, Hex Head Blk	SC9	2
15	6 X 1/2 Fenderwasher SST	20001X002	1
16	Washer Circuit Board	20111X014	1
17	6-32 X 5/16" Phillips, Pan Head	SC2	1
21	10-24 X 3/4" Screw SST	20001X001	2

FILTER VALVE

REF	DESCRIPTION	PART NO.	QTY
1	Piston Assembly	20001X231	1
2	10-24 X 3/4" Screw SST	20001X001	3
3	Seal and Spacer Kit Incl (5) #3 & (4) #4	20561X253	1
4	End Spacer	20001X234	1
5	Flow Control Button 5.0 GPM	20251X272	1
	Flow Control Button 7.0 GPM	20251X273	1
6A	DLFC Assy.	20017X251	1
7	90 Degree Hose Barb Elbow	20017X266	1
8	Brine Valve Plug w/ O-Ring	20001X230	1
9	Filter Plug Assy. w/ O-Ring	20001X229	1
10	10-24 X 3/4" Screw SST	20001X001	2
11	Injector Cap	20001X223	1
12	Injector Seal	20001X224	1
13	Injector Plug & O-Ring Assy.	20001X217	1
14	Injector Screen	20001x222	1
15	Injector Plug & O-Ring Assy.	20001X217	1
16	Valve O-Ring	20015X043	1
17	Dist. O-Ring	20561X204	1
18	Meter Assembly	20017X203	

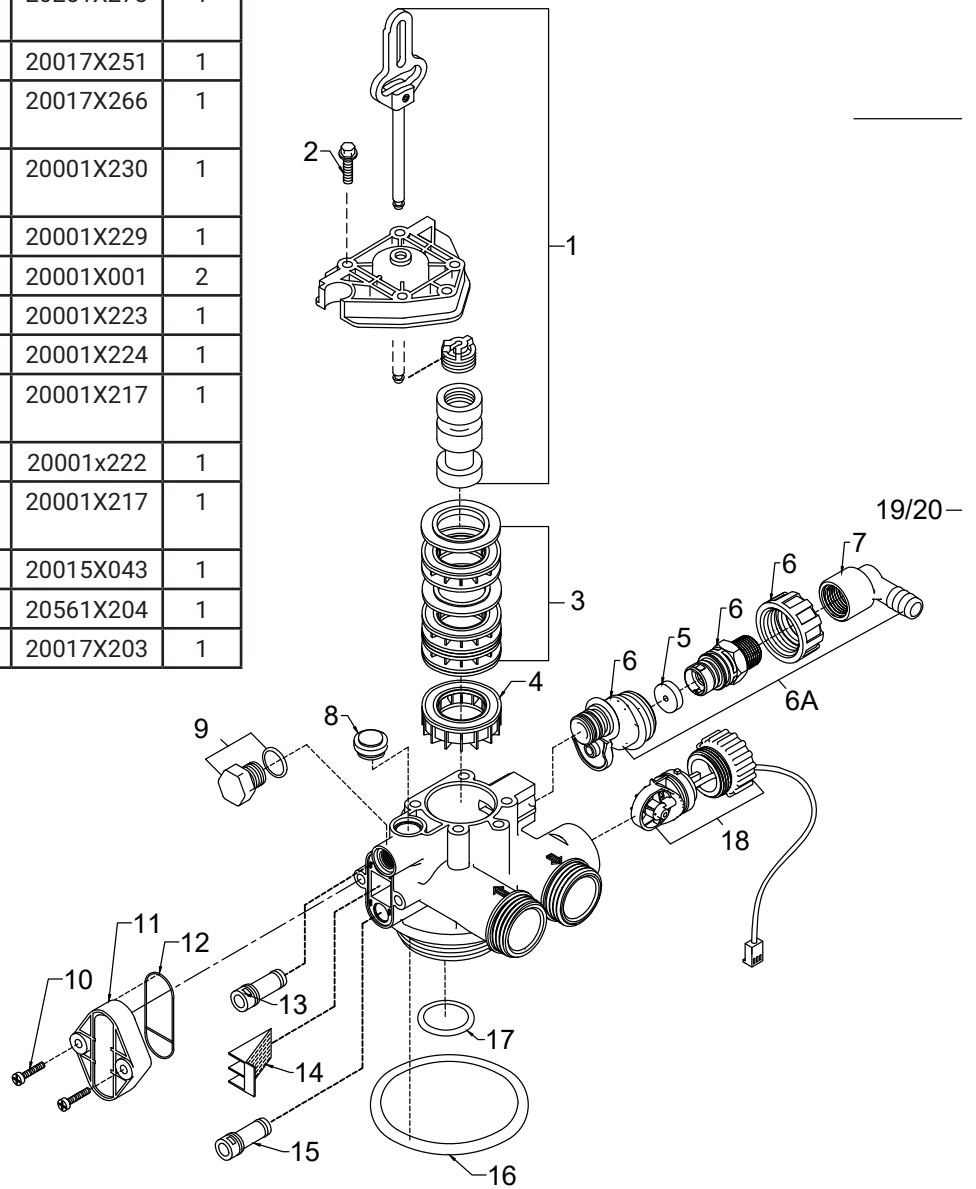

FILTER POWERHEAD

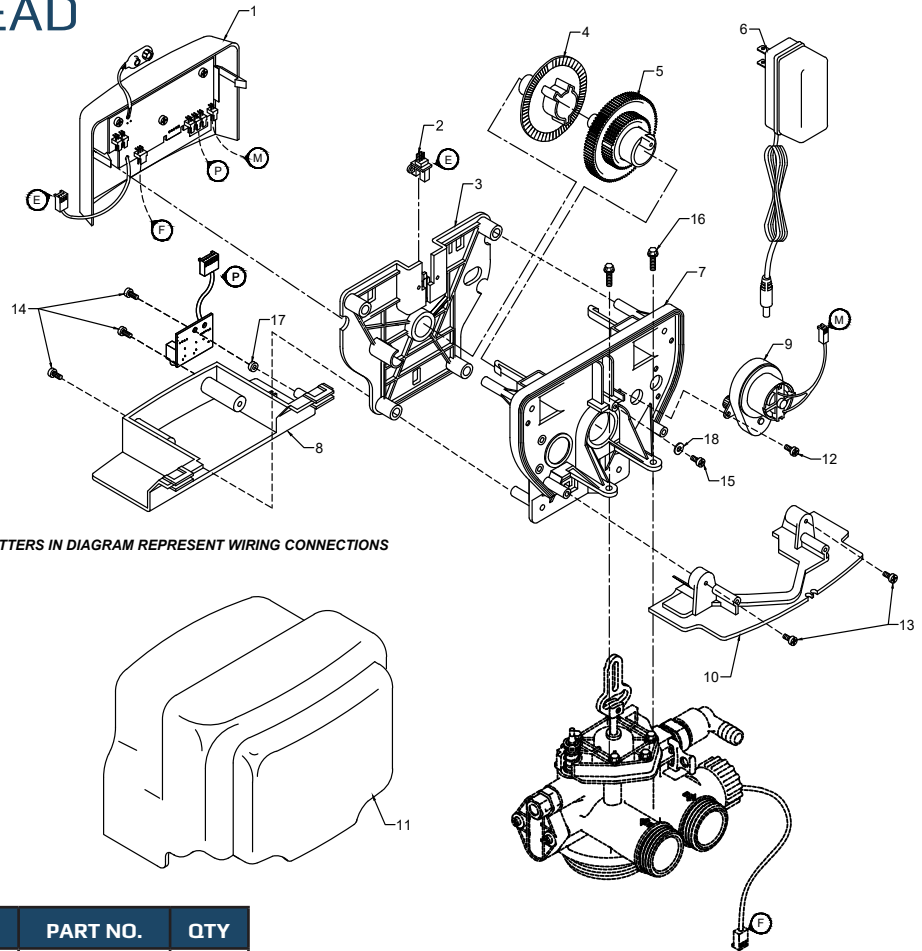

REF	DESCRIPTION	PART NO.	QTY
0	Power Head Assy.	21002X100	1
1	Filter Circuit Boad Assy.	21002X101	1
2	Encoder	20001X124	1
3	Front Plate	20001X004	1
4	Encoder Wheel	20001X007	1
5	Main Gear	21001X120	1
6	Power Supply	20001X125	1
7	Back Plate	20001X005	1
8	Lower Front Base For Cover	20111X002	1
9	Motor	20016X006	1
10	Lower Back Base for Cover	20111X003	1
11	Valve Cover	20111X000	1
12	Piston Screw	20001X003	1
13	Screw	SC10	3
14	Screw	SC9	2
15	6 X 1/2 Fenderwasher SST	20001X002	1
16	Washer Circuit Board	20111X014	1
17	Screw Motor	SC2	1
21	Valve Hex Screw	20001X001	2

AERATION VALVE

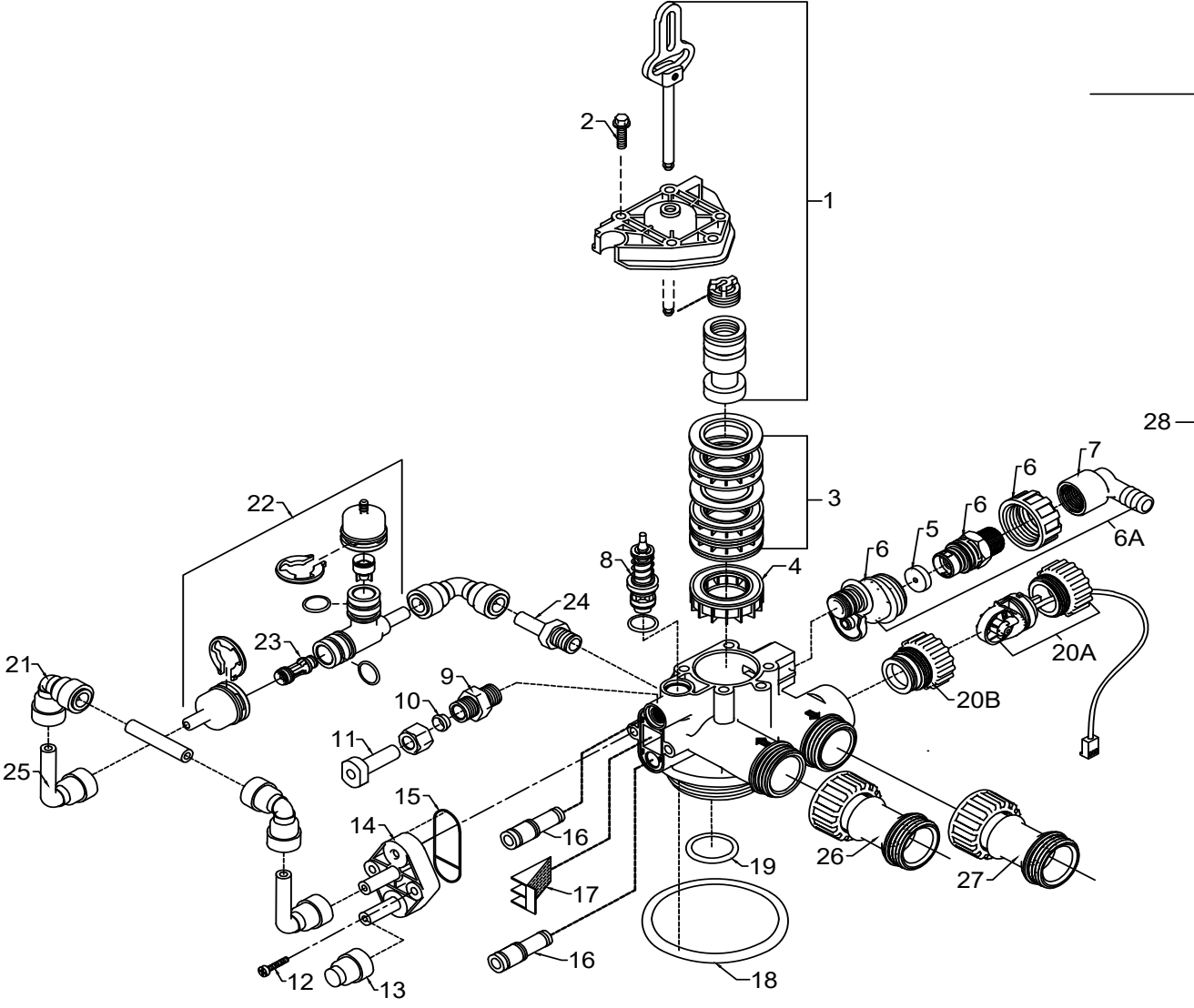

AERATION VALVE

REF	DESCRIPTION	PART NO.	QTY
1	Final Rinse Piston Assembly	20009X231	1
2	10-24 X 3/4" Screw SST	20001X001	3
3	Seal and Spacer Kit Incl (5) #3 & (4) #4	20561X253	1
4	End Spacer	20001X234	1
5	Flow Control Button 5.0 GPM	20251X272	1
	Flow Control Button 7.0 GPM	20251X273	1
6A	DLFC Housing	20017X251	1
7	90 Degree Hose Barb Elbow	20017X266	1
8	Brine Valve	20009X225	1
9	BLFC Assy. SST	20009X228	1
10	BLFC Ferrule 3/8"	20251X305	1
11	Plug 3/8"	20009X005	1
12	10-24 X 1" Screw SST	20001X226	2
13	3/8" Push Lock Plug	20009X010	1
14	Injector Cap	20009X001	1
15	Injector Seal	20001X224	1
16	Injector Plug & O-Ring Assy	20001X217	1
17	Injector Screen	20001X222	1
18	Tank / Valve O-Ring	20015X043	1
19	Dist. O-Ring	20561X204	1
20a	Meter Assembly	20017X203	1
20b	Meter Plug w/ O-Ring	20017X201	1
21	3/8" Push Lock 90 ° Elbow	GA-Q0620626BV	1
22	Air Injector Check Assy	20017X010	1
23	Injector Assy. #1 White	20017X219-1	1
24	Stem Adapter 1/4 NPT TO 3/8 JG	GA-S0660416B	1
25	John Guest to Stem Elbow	20015X021	2
26	Inlet Check Valve	20017X293	1
27	Extension	20017X292	1
28	Valve Body	N/A	1

AERATION POWERHEAD

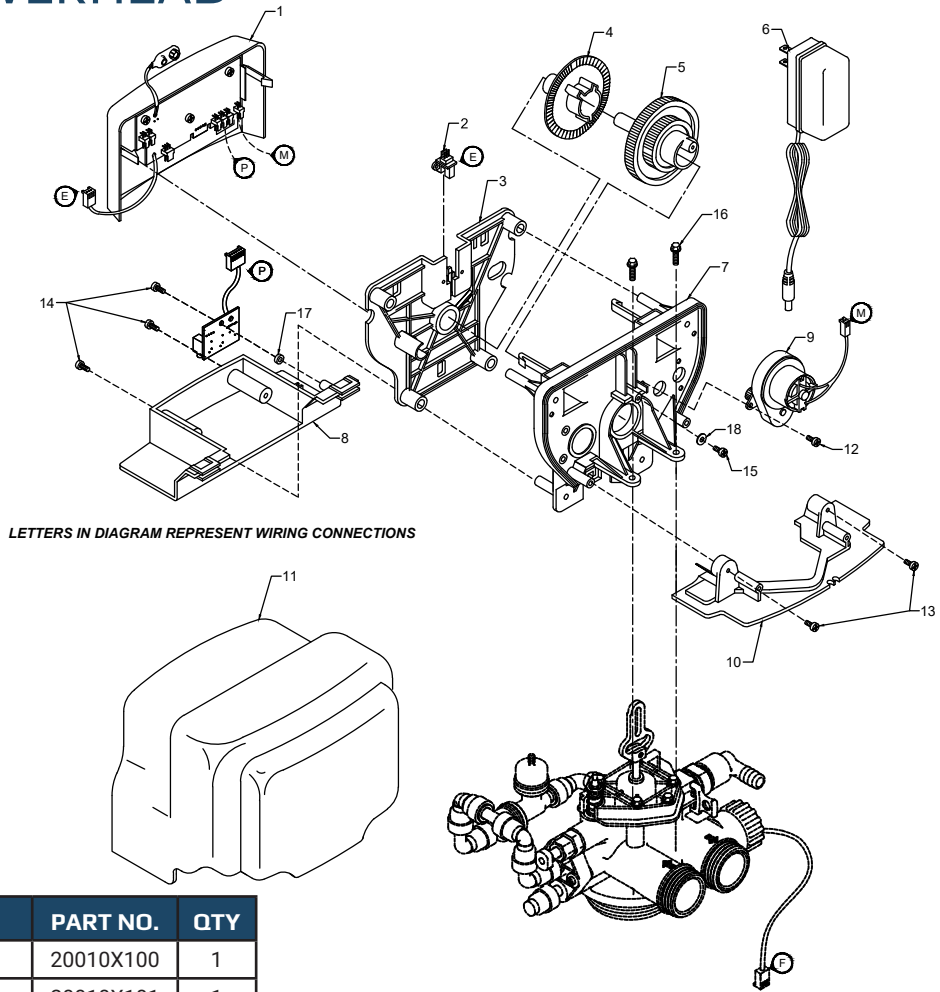

REF	DESCRIPTION	PART NO.	QTY
0	Powerhead Assy.	20010X100	1
1	Circuit Board Assy.	20010X101	1
2	Encoder	20001X124	1
3	Front Plate	20001X004	1
4	Encoder Wheel	20001X007	1
5	Main Gear	21001X120	1
6	Power Supply	20001X125	1
7	Back Plate	20001X005	1
8	Lower Front Base For Cover	20111X002	1
9	Motor	20016X006	1
10	Lower Back Base For Cover	20111X004	1
11	Slide Cover	20111X003	1
12	Motor Screw	SC2	4
13	Screw	SC9	2
14	Screw	SC10	3
15	Piston Screw	20001X007	1
16	Valve Hex Screw	20001X001	2
17	Circuit Board Washer	20111X014	1
18	Piston Washer	20001X002	1

SIDE VALVE

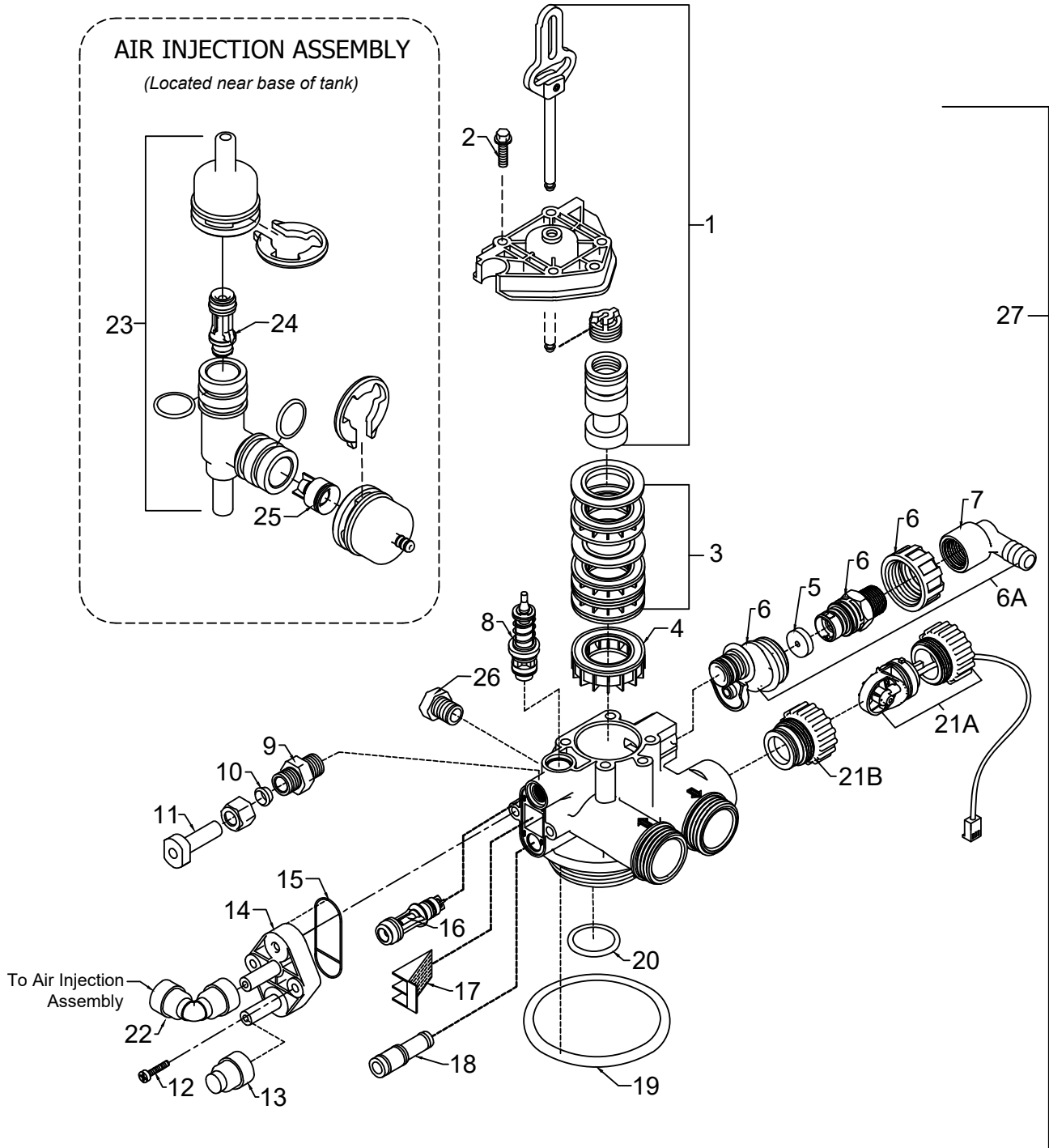

SIDE VALVE

REF	DESCRIPTION	PART NO.	QTY
1	Piston Assembly Final Rinse	20009X231	1
2	10-24 X 3/4" Screw SST	20001X001	5
3	Seal and Spacer Kit	20561X253	1
4	End Spacer	20001X234	1
5	Flow Control Button 5.0 GPM	20251X272	1
	Flow Control Button 7.0 GPM	20251X273	1
6A	DLFC Housing	20017X251	1
7	Drain Line Hose Barb 90 ° Elbow	20017X266	1
8	Brine Valve	20009X225	1
9	BLFC Assy. SST	20009X228	1
10	BLFC Ferrule 3/8"	20251X305	1
11	Plug 3/8"	20009X005	1
12	10-24 X 3/4" Screw SST	20001X226	2
13	3/8" Push Lock Plug	20009X010	1
14	Injector Cap	20009X001	1
15	Injector Seal	20001X224	1
16	Injector Assy. #1 White	20017X219	1
17	Injector Screen	20001X222	1
18	Injector Plug & O-Ring Assy	20001X217	1
19	Tank / Valve O-Ring	20015X043	1
20	Dist. O-Ring	20561X204	1
21a	Meter Assembly	20017X203	1
21b	Meter Plug w/ O-Ring	20017X201	1
22	3/8" Push Lock 90 ° Elbow	GA-Q0620626BV	1
23	Air Injector Check Assy	20017X010	1
24	Injector, White	20017X219	1
25	Check Valve	20017X009	1
26	1/4" NPT Cap	20018X035	1

SIDE POWERHEAD

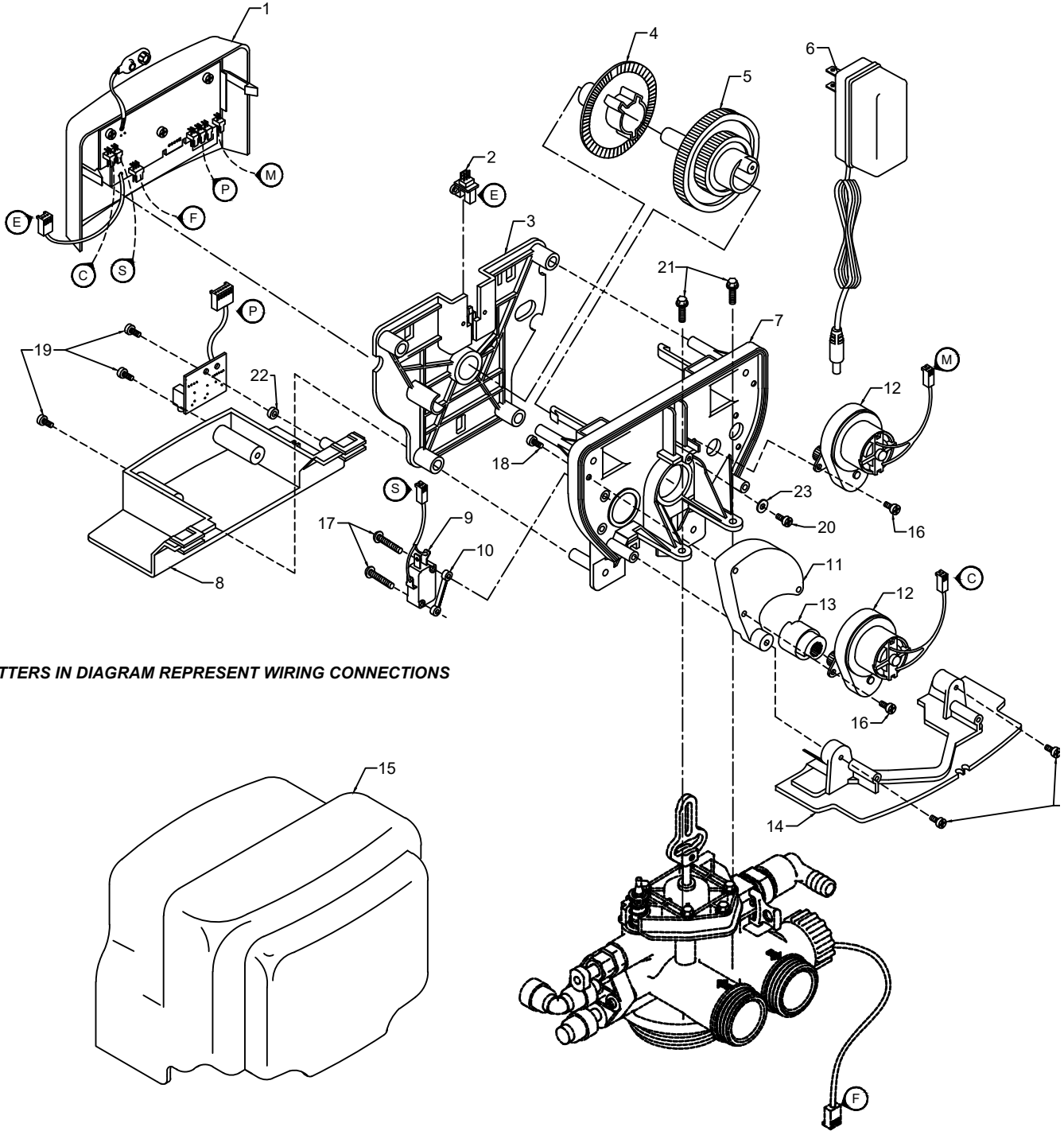

LETTERS IN DIAGRAM REPRESENT WIRING CONNECTIONS

SIDE POWERHEAD

REF	DESCRIPTION	PART NO.	QTY
0	Powerhead Assy.	20015X100	1
1	Circuit Board Assy.	22015X101	1
2	Encoder	20001X124	1
3	Front Plate	20001X004	1
4	Encoder Wheel	20001X007	1
5	Main Gear	21001X120	1
6	Power Supply	20001X125	1
7	Back Plate	20001X005	1
8	Lower Front Base For Cover	20111X002	1
9	Microswitch	20251X113	1
10	Switch Spacer	20111X004	1
11	Brine Motor Mount	20111X006	1
12	Legacy View Motor Assy.	20016X006	2
13	Brine Cam	20111X005	1
14	Lower Back Base For Cover	20111X003	1
15	Valve Cover	20111X000	1
16	6-32 X 5/16" Phillips, Pan Head	SC2	4
17	4 X 3/4" Phillips, Oval Head	SC3	2
18	6 X 1/2" Slotted, Hex Head Black	SC9	3
19	6 X 1/2" Phillips, Pan Head	SC10	3
20	6 X 1/2" Slotted, Hex Head	20001X003	1
21	10-24 X 3/4" Screw SST	20001X001	2
22	Circuit Board Washer	20111X014	1
23	6 X 1/2 Fenderwasher SST	20001X002	1

BYPASS ASSEMBLY

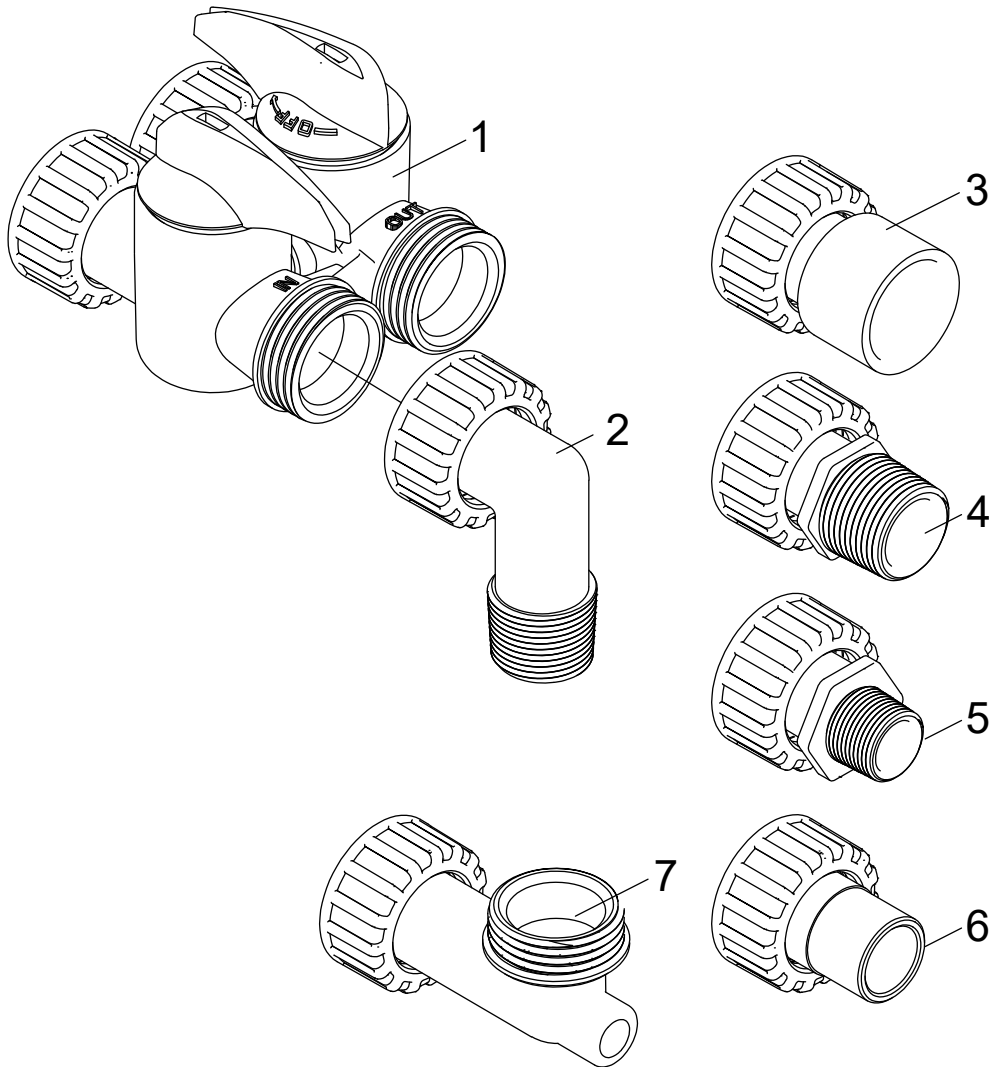

REF	DESCRIPTION	PART NO.
1	D15 Bypass (included with all units)	20017X283
2	1" NPT Elbow Set (included with all units)	20017X284
3	1" Female Straight Slip Set (optional)	20017X288
4	1" NPT Straight Set (optional)	20017X289
5	3/4" NPT Straight Set (optional)	20017X307
6	1" X 3/4" Brass Sweat Connector Set (optional)	20017X304
7a	Elbow, Vertical Adapter Blank (optional)	20017X295
7b	Elbow, Vertical Adapter 1/4" NPT Tapped (optional)	20017X294

SERVICE INSTRUCTIONS

A. General Preliminary Instructions

PERFORM BEFORE ALL SERVICING OPERATIONS

1. Turn off water supply to conditioner.
 - If the conditioner installation has a “three valve” bypass system, first open the valve in the bypass line, then close the valves at the conditioner inlet and outlet.
 - If the conditioner has an integral bypass valve, put it in the bypass position.
 - If there is only a shut off valve near the conditioner inlet, close it.
2. Remove cover and relieve water pressure in the conditioner by stepping the control into the backwash position momentarily. Return the control to the service position.
3. Unplug electrical cord from outlet.

B. To Replace Powerhead

1. Remove the control valve cover and disconnect the power supply.
2. Disconnect the meter cable from circuit board and feed back through control (if existing meter is being re-used)
3. Remove lower back base screws and detach lower back base.
4. Remove screw and washer at drive yoke. Remove powerhead mounting screws. The entire powerhead assembly will now lift off easily.
5. Put new powerhead on top of the valve. Be sure the drive pin on main gear engages slot in drive yoke (wideside of drive yoke upright must face to the left away from the motor).
6. Replace powerhead mounting screws. Replace screw and washer at drive yoke.
7. Reattach lower back base.
8. Reconnect meter signal, wire and power supply.
9. Reinstall cover.

C. To Replace Piston Assembly

1. Follow steps **A1 - A3**
2. Disconnect the meter signal wire from the circuit board.
3. Remove lower back base screws and detach lower back base.
4. Remove screw and washer at piston drive yoke. Remove powerhead mounting screws. The entire powerhead assembly will now lift off easily.
5. Remove piston retaining plate screws.
6. Pull upward on end of piston yoke until assembly is out of valve.
7. Inspect the inside of the valve to make sure that there is no foreign matter that would interfere with the valve operation.
8. Install new seals and spacers.
9. Take new piston assembly and push piston into valve by means of the end plug. Twist drive yoke care fully in a clockwise direction to properly align it with drive gear. Reinstall piston retaining plate screws.
10. Follow steps **B5 - B9**

SERVICE INSTRUCTIONS

D. To Replace Seals and Spacers

1. Follow steps **A1 - A3**.
2. Disconnect the meter signal wire from the circuit board.
3. Remove screw and washer at piston drive yoke. Remove powerhead mounting screws. The entire powerhead assembly will now lift off easily. Remove piston retaining plate screws.
4. Pull upward on end of piston rod yoke until assembly is out of valve. Remove seals and spacers.
(**Note:** Special end spacer must be reused)
5. Lubricate new seals with silicone lubricant included in the seal and spacer kit. Make sure the special end spacer is properly seated in the valve body. Install new seals and spacers individually, pressing around the outer edge of each seal to make sure it is seated. (When all seals and spacers are seated properly, you will have a 1/4" of space between the top seal the the top of the valve body)
6. Follow Steps **C9 - C10**.

E. To Service Injector and Screen

1. Follow steps A1-A2.
2. Unscrew injector cover screws and remove injector cover.
3. Remove injector screen and clean or replace.
4. Remove injector and clean or replace.
5. Apply silicone lubricant to injector seal and replace cover and screws.

F. To Replace Meter

1. Follow steps **A1 - A3**
2. Unplug meter cable from front of circuit board.
3. Unscrew meter assembly nut from valve body.
4. Remove meter from valve body and clean or replace as necessary.
5. Reinstall meter, nut and cable.

G. To Replace Brine Valve

1. Follow Piston Replacement instructions. After the piston is removed, pull the brine valve from the valve body.
2. Inspect brine valve cavity in valve body and remove any foreign matter that would interfere with brine valve operation.
3. Apply silicone lubricant to brine valve O rings and push the new brine valve into the valve body.
4. Continue following Piston Replacement instructions to reinstall piston and powerhead

Error Codes

There are five (7) error codes that could indicate a possible problem with the control valve:

Error 2 - Homing slot expected. Valve will start looking for home. (Normal operation continues)

Error 3 - Encoder is not sending a signal (Valve requires service to continue)

Error 4 - Unable to find homing slot (Valve requires service to continue)

Error 5 - Motor overload /stalled position or shorted motor (Valve requires service to continue)

Error 6 - No motor current (check motor is unplugged from control board)

Error 7 - No microswitch detected (verify the microswitch is plugged in and the button isn't stuck down)

TROUBLESHOOTING

SYMPTOM	PROBABLE CAUSE	CORRECTION
1. Softener Fails to Regenerate Automatically	Power supply plugged into intermittent or dead power source	Connect to constant power source
	Disconnected meter cable	Reconnect cable
	Improper control valve programming	Reset program settings
	Defective power supply	Replace power supply
	Meter is dirty or defective	Clean or replace meter assembly
	Defective Drive motor	Replace motor
2. Regeneration at Wrong Time	Time of day improperly set, due to power failure	Reset time of day programming and install 9-volt battery.
	Regeneration time set improperly	Reset regeneration time programming
3. Loss of Capacity	Increased raw water hardness	Increase hardness setting or decrease days between regeneration
	Brine concentration and or / quantity	Keep brine tank full of salt at all times. Clean it yearly. Salt may be bridged. If using a salt grid plate, ensure refill water is over it.
	Resin fouling	Call dealer. Find out how to confirm it. Clean the resin and prevent future fouling.
	Poor distribution, channeling (uneven bed surface)	Call dealer. Check backwash flow. Regenerate more frequently
	Internal valve leak	Call dealer. Replace spacers, seals and / or piston
	Resin age	Call dealer. Check for resin oxidation caused by chlorine. Mushy resin.
	Resin loss	Call dealer. Check for correct bed depth. Broken distributor tube. Air or gas in bed: well gas eliminator. Loose brine line.
4. Poor Water Quality	Check items listed in #1, #2, and #3	
	Bypass valve open	Close bypass valve.
	Channeling	Check for too slow or high service flow. Check for media fouling.
5. High Salt Usage	High salt setting	Lower brine tank refill time
	Excessive water in brine tank	See symptom #7
	Constant flow through the unit	Indicates plumbing leak (e.g. toilet tank)
	Regenerating too frequently	Lower hardness setting or increase days between regeneration.

VALVE DIMENSIONS

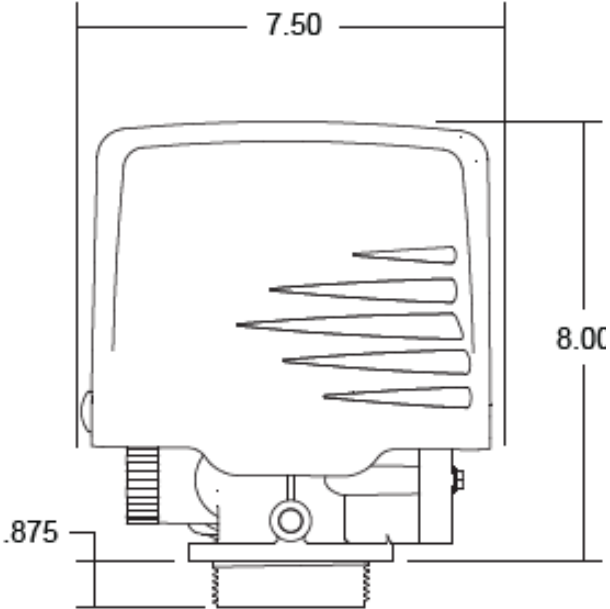
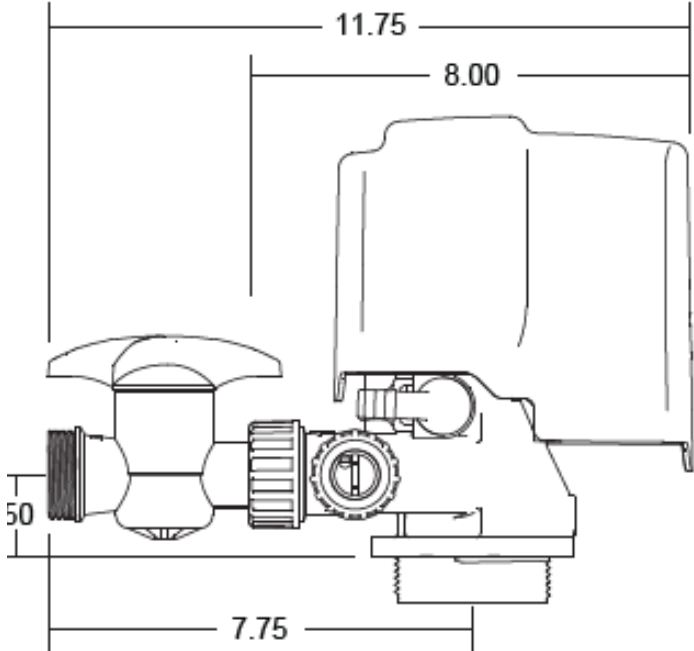



WATER TREATMENT EQUIPMENT

This warranty cannot be transferred - it is extended only to the product's original purchaser or first user. By accepting and keeping this product, you agree to all the warranty terms and limitations of liability described below.

Important Warning: Read the BlueStream™ Equipment Installation, Operating, and Maintenance Instructions Manual carefully to avoid serious personal injury and property HAZARDS and to ensure safe and proper care of this product.

*FOR AS LONG AS YOU OWN AND LIVE IN YOUR SINGLE-FAMILY HOME, this warranty covers your water treatment equipment if you are the first user of this BlueStream™ water treatment equipment and purchased it for single-family home use - subject to all of the conditions, limitations, and exclusions listed below. Purchasers who buy the BlueStream™ water treatment equipment for other purposes and other component parts are subject to more limited warranties, and you should read all the terms included in this form to ensure you understand your warranty. What is covered by this warranty? BlueStream warrants that at the time of manufacture, the water treatment equipment shall be free from defects in material and workmanship as follows:

Proprietary Control Valves.....7 years
Other Softener/Filter Control Valves.....5 years

Additional Terms & Conditions

What BlueStream™ will do if you have a covered warranty claim BlueStream™ will, at its option, either make repairs to correct any defect in material or workmanship or supply and ship either new or used replacement parts or products. BlueStream will not accept any claims for labor or other costs.

Additional Exclusions and Limitations

This warranty is non-transferable and does not cover any failure or problem unless it was caused solely by a defect in material or workmanship. In addition, this warranty shall not apply:

- If the water treatment equipment is not correctly installed, operated, repaired, and maintained as described in the Installation, Operating & Maintenance Instructions Manual provided with the product.
- Defects are caused as a direct result of the incoming water quality.
- If the tank is not the size indicated for the supply line size of the installation, as described in the manual.
- If the unit has not always been operated within the factory-calibrated temperature limits and at a water pressure not exceeding 125 psi
- To any failure or malfunction resulting from abuse (including freezing), improper or negligent; handling, shipping (by anyone other than Chandler Systems, Inc.), storage, use, operation, accident; or alteration, lightning, flooding, or other environmental conditions.
- To any failure or malfunction resulting from failure to keep the unit full of potable water, free to circulate at all times, and with the tank free of damaging water sediment or scale deposits.
- This warranty does not cover labor costs, shipping charges, service charges, delivery expenses, property damage, administrative fees, or any costs incurred by the purchaser in removing or reinstalling the water treatment equipment.
- The warranty does not cover any claims submitted to Chandler Systems, Inc. more than 30 days after the expiration of the applicable warranty and does not apply unless prompt notice of any claim is given to an authorized BlueStream or a designated contractor is provided access to the installation and to the water treatment equipment.

THESE WARRANTIES ARE GIVEN IN LIEU OF ALL OTHER EXPRESS WARRANTIES. NO CHANDLER SYSTEMS, INC. REPRESENTATIVE OR ANY OTHER PARTY IS AUTHORIZED TO MAKE ANY WARRANTY OTHER THAN THOSE EXPRESSLY CONTAINED IN THIS WARRANTY AGREEMENT.

Additional Warranty Limitations

ANY IMPLIED WARRANTIES THE PURCHASER MAY HAVE, INCLUDING THE IMPLIED WARRANTIES OF MERCHANTABILITY AND FITNESS FOR A PARTICULAR PURPOSE, SHALL NOT EXTEND BEYOND THE APPLICABLE TIME PERIODS SPECIFIED ABOVE. Some states do not allow limitations on how long an implied warranty lasts, so the above limitations may not apply to you.

Limitations of Remedies

The remedies contained in this warranty are the purchaser's exclusive remedies. In no circumstances will Chandler Systems, Inc. or the product seller be liable for more than, and purchaser-user's remedies shall not exceed the price paid for the product. In no case shall BlueStream or the seller be liable for any special, incidental, contingent, or consequential damages. Special, incidental, contingent, and consequential damages for which Chandler Systems, Inc. is not liable include but are not limited to inconvenience, loss or damage to property, consequential mold damage, loss of profits, loss of savings or revenue, loss of use of the products or any associated equipment, facilities, buildings or services, downtime, and the claims of third parties including customers. Some states do not allow the exclusion or the limitation of incidental or consequential damages, so the above limitations or exclusion may not apply to you.

What to do if you have a problem covered by this warranty Any warranty coverage must be authorized by Chandler Systems, Inc. Contact the person from whom you purchased the product, who must receive authorization from BlueStream.

If your product is new and unused and you wish to return it, contact BlueStream.

